

## Absolute Rotary Encoder

## E6C2-A

The Tough E6C2-A Absolute Rotary Encoder Provides IP64 Degree of Protection and Ensures Ease of Use in Combination with the Programmable Controller or Cam Positioner.

■ IP64 (IEC529) for Durability

The E6C2-A is a compact model that is 38 mm in length and 50 mm in diameter. It also incorporates a seal bearing, thus meeting IP64.

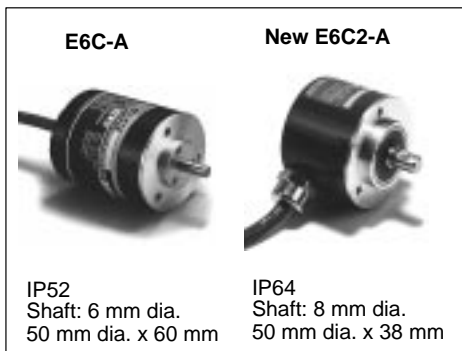

■ Shaft is Approximately Twice as Strong as Conventional Shafts

The E6C2-A has a stainless steel shaft that is 8 mm in diameter and approximately twice as strong as OMRON's conventional Rotary Encoder shaft. The E6C2-A also has a reliable bearing and metal slit plate, thus ensuring a shock resistance of 1,000 m/s<sup>2</sup>.

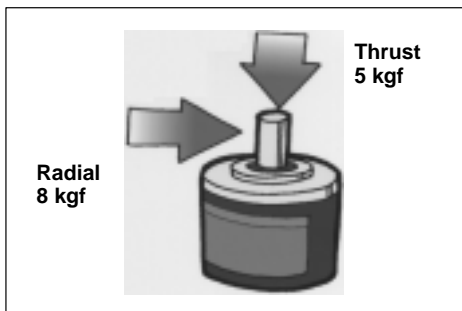

■ Combines with the Programmable Controller or Cam Positioner for Ideal Angle Control

The E6C2-A resolution per rotation is as high as 256 (8 bits) to 1,024 (10 bits). The E6C2-A used in combination with the CQM1 Programmable Controller or H8PS Cam Positioner ensures ideal and easy angle control.

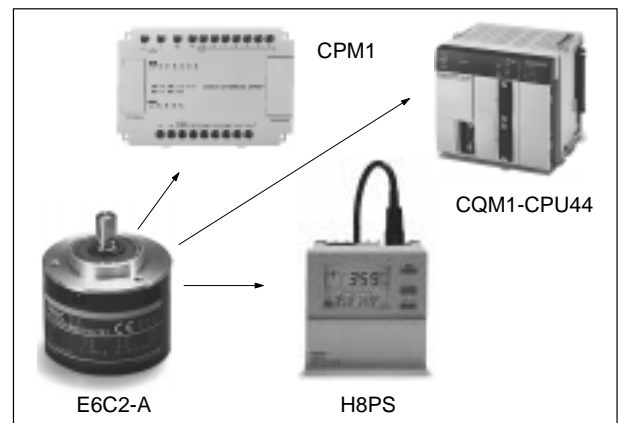

# Ordering Information

## Absolute Rotary Encoders

Supply voltage	Output configuration	Output code	Resolution (p/r)	Connection method	Model
12 to 24 VDC	NPN open collector output	Gray code	256	Connector	E6C2-AG5C-C
			256, 360, 720, 1,024	Pre-wired	E6C2-AG5C
		Binary	32, 40		E6C2-AN5C
	BCD	6, 8, 12	E6C2-AB5C		
	PNP open collector output	Gray code	256, 360, 720, 1,024	E6C2-AG5B	
		Binary	32, 40	E6C2-AN5B	
BCD		6, 8, 12	E6C2-AB5B		
5 VDC	Voltage output	Binary	256	E6C2-AN1E	
12 VDC				E6C2-AN2E	

- Note:**
- When ordering, specify the model number and resolution.
  - The H8PS can be connected to the E6C2-AG5C-C but not to the E6C2-AG5C.

### ■ Accessories (Order Separately)

Refer to page 15 for details.

Item	Model
Coupling	E69-C08B
Flange	E69-FCA03
	E69-FCA04
Extension Cable (see note)	E69-DF5

- Note:** In addition to the above Extension Cable, 10-, 15- 20-, and 98-m-long Extension Cables are available.

## Application Examples

**NC Machine Tool for Cutter Position Detection**

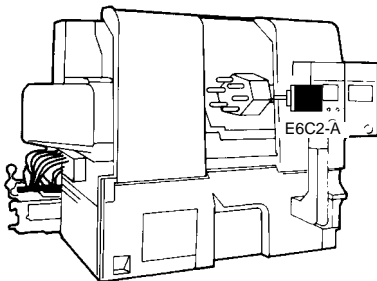

**Vacuum Packaging Machine**

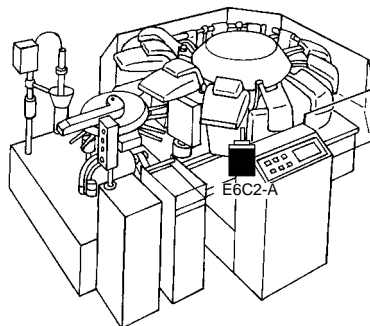

**Bottling Machine for Table Position Detection**

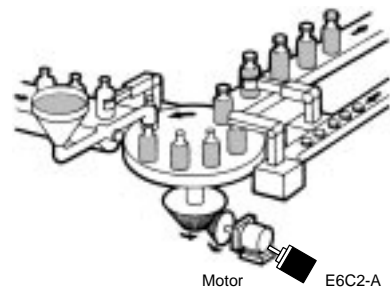

# Specifications

## ■ Ratings/Characteristics

Item	E6C2-AG5C-C	E6C2-AG5C	E6C2-AN5C	E6C2-AB5C	E6C2-AG5B	E6C2-AN5B	E6C2-AB5B	E6C2-AN1E	E6C2-AN2E
Output configuration	NPN				PNP			Voltage output	
Power supply voltage	12 VDC <sup>-10%</sup> to 24 VDC <sup>+15%</sup> , ripple (p-p) 5% max.							5 VDC ±5%	12 VDC ±10%
Current consumption	70 mA max.								80 mA max.
Resolution (see note 1) (pulses/rotation)	256	256, 360, 720, 1,024	32, 40	6, 8, 12	256, 360, 720, 1,024	32, 40	6, 8, 12	256	
Output code (absolute)	Gray code		Binary	BCD	Gray code	Binary	BCD	Binary	
Output capacity	Applied voltage: 30 VDC max. I <sub>sink</sub> : 35 mA max. Residual voltage: 0.4 V max. (at sink current of 35 mA)				I <sub>sink</sub> : 35 mA max. Residual voltage: 0.4 V max. (at sink current of 35 mA)			Output re- sistance: 2.4 kΩ	Output resistance: 8.2 kΩ
Rise and fall times of output	1 μs max. (cable length: 2m; I <sub>sink</sub> : 35 mA max.)							Rise: 3 μs max. Fall: 1 μs max.	Rise: 10 μs max. Fall: 1 μs max.
Max. response frequency (see note 2)	20 kHz							10 kHz	
Logic	Negative logic output (H=0, L=1)				Positive logic output (H=1, L=0)				
Rotational direction (see note 3)	Output code incremented by clockwise rotation (as viewed from the face of the shaft.)							Changed using the rotational direction designation input.	
Strobe signal	Not available		Available		Not available	Available		Not available	
Positioning signal	Not available			Available	Not available		Available	Not available	
Parity signal	Not available		Available (even number)	Not available		Available (even number)	Not available		
Starting torque	9.8 mN • m max. at room temperature 14.7 mN • m max. at low temperature								
Moment of inertia	1.5 x 10 <sup>-6</sup> kg • m <sup>2</sup>								
Shaft loading	Radial: 78.4 N Thrust: 49 N								
Maximum permissible rotation	5,000 rpm								
Ambient temperature	Operating: -10°C to 70°C (with no icing) Storage: -25°C to 85°C (with no icing)								
Ambient humidity	35% to 85% (with no condensation)								
Insulation resistance	1,000 MΩ min. (at 500 VDC) between current-carry parts and case								
Dielectric strength	500 VAC, 50/60 Hz for 1 min between current-carry parts and case								
Vibration resistance	Destruction: 10 to 500 Hz, 1.0-mm single amplitude or 150 m/s <sup>2</sup> for 11 min. 3 times each in X, Y, and Z directions.								
Shock resistance	Destruction: 1,000 m/s <sup>2</sup> , 6 times each in X, Y, and Z directions								

Item	E6C2-AG5C-C	E6C2-AG5C	E6C2-AN5C	E6C2-AB5C	E6C2-AG5B	E6C2-AN5B	E6C2-AB5B	E6C2-AN1E	E6C2-AN2E
Degree of protection	IEC60529 IP64 (see note 4)								
Connection method	Connector (standard length: 2 m)	Pre-wired (standard length: 2m)							
Weight (packed state)	Approx. 300 g								
Others	Instruction manual								

Note: 1. The codes are classified as shown in the following table.

Output code	Resolution	Code number
Binary	32	1 to 32
	40	1 to 40
	256	0 to 255
BCD	6	0 to 5
	8	0 to 7
	12	0 to 11
Gray code	256	0 to 255
	360	76 to 435 (Remainder of 76)
	720	152 to 871 (Remainder of 152)
	1,024	0 to 1,023

2. The electrical maximum response rotation is determined by using the resolution and maximum response frequency in the following formula.

$$\text{Electrical maximum response rotation (rpm)} = \frac{\text{Maximum response frequency}}{\text{Resolution}} \times 60$$

Therefore, a signal cannot follow electrically if the actual rotation exceeds the maximum response rotation.

3. With the E6C2-AN1E and E6C2-AN2E models, the output code can be increased in the clockwise direction by connecting the rotational direction designation input (wire color: pink) to H (Vcc), and the output code can be decreased in the clockwise direction by connecting the input to L (0 V).

E6C2-AN1E: H=1.5 to 5 V, L=0 to 0.8 V

E6C2-AN2E: H=2.2 to 12 V, L=0 to 1.2 V

With the E6C2-AN1E and E6C2-AN2E models, read the code at least 10 μs after the LSB (2<sup>0</sup>) code has changed.

4. JEM1030: applicable since 1991.

## ■ Construction

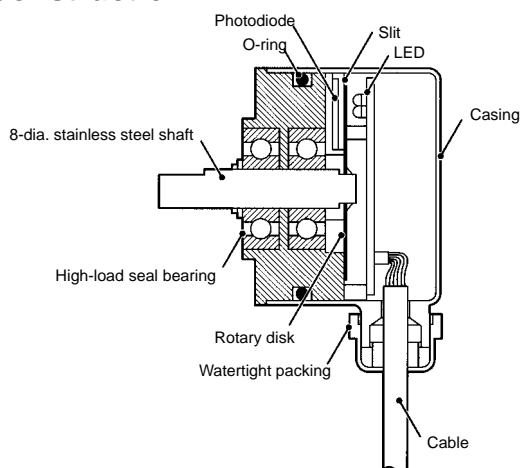

The E6C2-A incorporates a high-performance LED, custom-made diode array, high-density printed circuit board, and a compact, watertight, seal bearing that withstands heavy loads, thus ensuring high mechanical durability, watertight performance, and compactness. Furthermore, the O-ring applied to the casing and a watertight packing applied to the cable connector enhance the watertight performance of the E6C2-A.

# Operation

## ■ Connections

### Connector Specifications

Pin number	E6C2-AG5C-C	
	Output signal	
	8-bit (256)	
1	NC	
2	NC	
3	$2^5$	
4	$2^1$	
5	$2^0$	
6	$2^7$	
7	$2^4$	
8	$2^2$	
9	$2^3$	
10	$2^6$	
11	Shield (GND)	
12	12 to 24 VDC	
13	0 V (Common)	

**Note:** Connector type: RP13A-12PD-13SC (Hirose Electric)

### Cable Specifications

Wire color	E6C2-AG5C/E6C2-AG5B			E6C2-AN5C/ -AN5B	E6C2-AB5C/AB5B		E6C2-AN1E/ AN2E	
	Output signal			Output signal	Output signal		Output signal	
	8-bit (256)	9-bit (360)	10-bit (720, 1,024)	6-bit (32, 40)	3-bit (6, 8)	5-bit (12)	8-bit (256)	
<b>Brown</b>	$2^0$	$2^0$	$2^0$	$2^0$	$2^0$	$2^0$	$2^0$	
<b>Orange</b>	$2^1$	$2^1$	$2^1$	$2^1$	$2^1$	$2^1$	$2^1$	
<b>Yellow</b>	$2^2$	$2^2$	$2^2$	$2^2$	$2^2$	$2^2$	$2^2$	
<b>Green</b>	$2^3$	$2^3$	$2^3$	$2^3$	NC	$2^3$	$2^3$	
<b>Blue</b>	$2^4$	$2^4$	$2^4$	$2^4$	NC	$2^0 \times 10$	$2^4$	
<b>Purple</b>	$2^5$	$2^5$	$2^5$	$2^5$	NC	NC	$2^5$	
<b>Gray</b>	$2^6$	$2^6$	$2^6$	Parity	Positioning	Positioning	$2^6$	
<b>White</b>	$2^7$	$2^7$	$2^7$	Strobe	Strobe	Strobe	$2^7$	
<b>Pink</b>	NC	$2^8$	$2^8$	NC	NC	NC	Rotational direction designation input	
<b>Light blue</b>	NC	NC	$2^9$	NC	NC	NC	NC	
---	Shield (GND)							
<b>Red</b>	12 to 24 VDC						5, 12 VDC	
<b>Black</b>	0 V (Common)							

■ Output Circuit Diagrams

E6C2-AG5C/-AG5C-C and E6C2-AG5B Output Circuits  
E6C2-AG5C/-AG5C-C

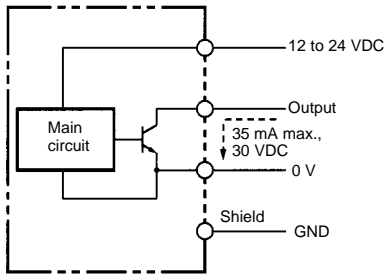

Note: Each output bit uses the same circuit.

E6C2-AG5B

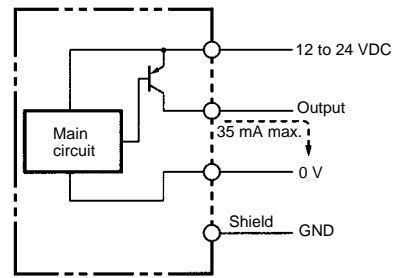

Note: Each output bit uses the same circuit.

E6C2-AG5C/-AG5C-C and E6C2-AG5B Output Modes

Rotating direction: CW, as viewed from the face of the shaft.

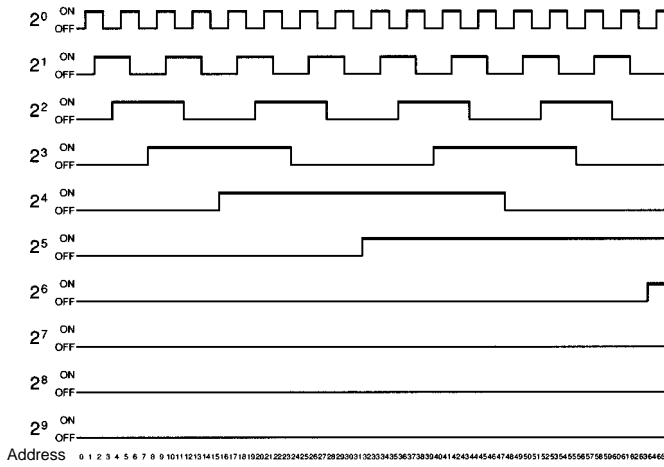

E6C2-AN5C and E6C2-AN5B Output Circuits  
E6C2-AN5C

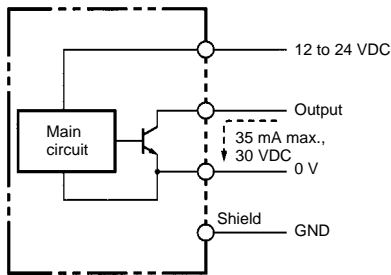

Note: Each output bit uses the same circuit.

E6C2-AN5B

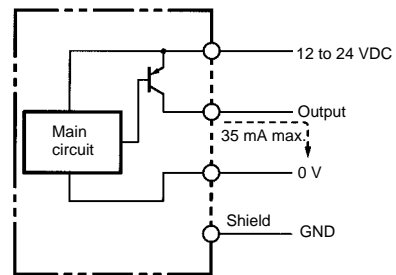

Note: Each output bit uses the same circuit.

**E6C2-AN5C and E6C2-AN5B Output Modes**

Rotating direction: CW, as viewed from the face of the shaft.

Resolution: 40

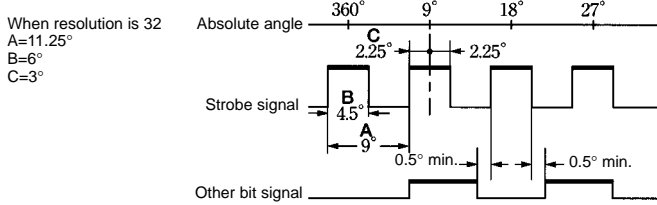
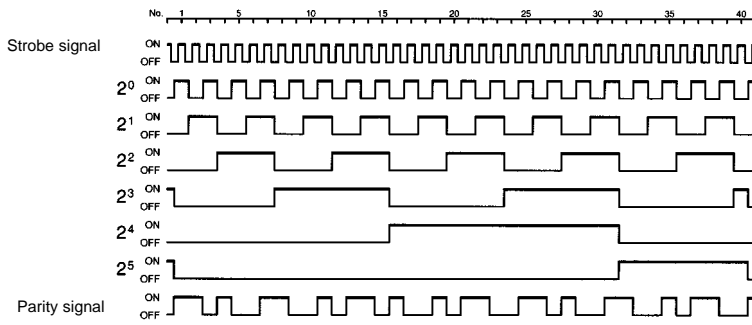

**E6C2-AB5C and E6C2-AB5B Output Circuits**

E6C2-AB5C

E6C2-AB5B

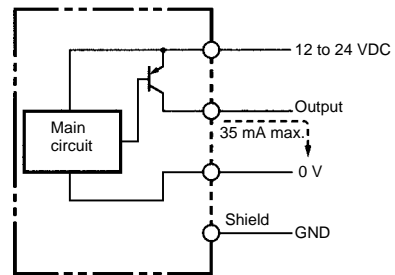
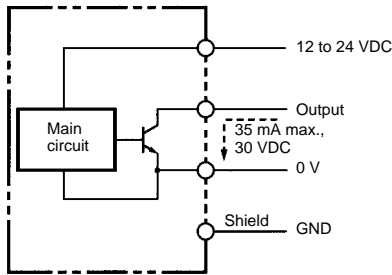

**Note:** Each output bit uses the same circuit.

**Note:** Each output bit uses the same circuit.

**E6C2-AB5C and E6C2-AB5B Output Modes**

Rotating direction: CW, as viewed from the face of the shaft.

Resolution: 12

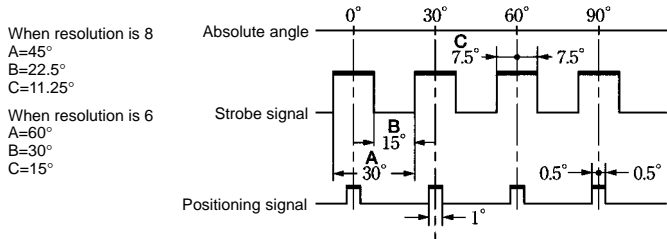
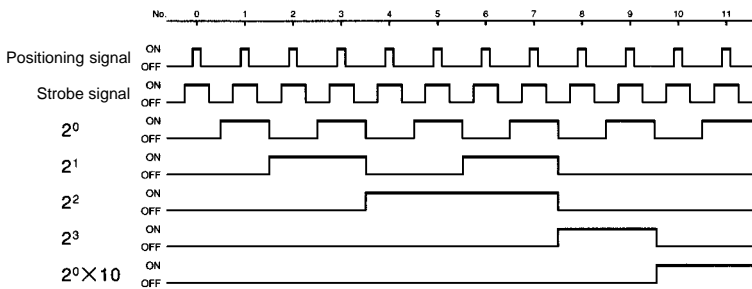

**E6C2-AN1E and E6C2-AN2E Output Circuits**  
E6C2-AN1E

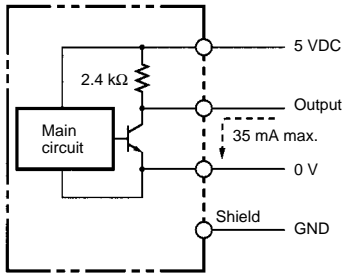

**Note:** Each output bit uses the same circuit.

**E6C2-AN2E**

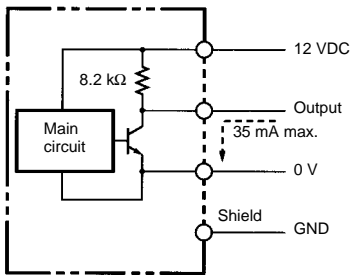

**Note:** Each output bit uses the same circuit.

**Rotational Direction Designation Input Circuit**

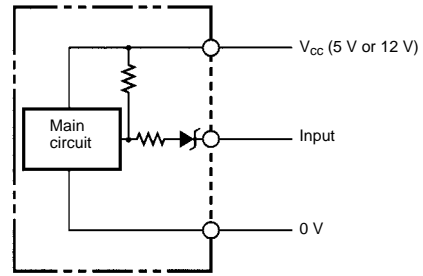

**Note:** Output code increases in the clockwise direction when the input is connected to Vcc and decreases in the clockwise direction when the input is connected to 0 V.

**E6C2-AN1E and E6C2-AN2E Output Modes**

Rotating direction: CW, as viewed from the face of the shaft, when rotational direction designation input is at "H."  
CCW, as viewed from the face of the shaft, when rotational direction designation input is at "L."

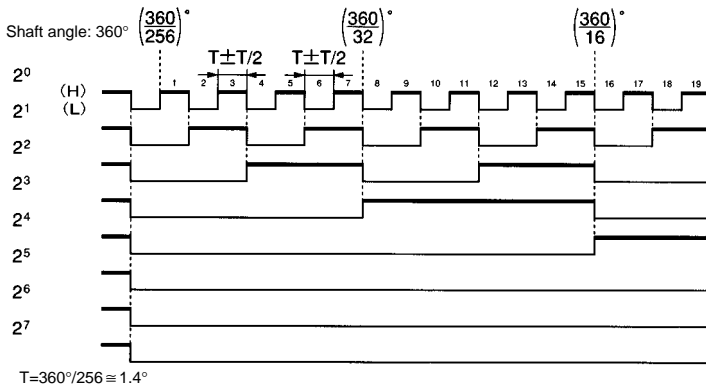

■ Connection Examples

Connecting E6C2-AG5C-C to H8PS Cam Positioner

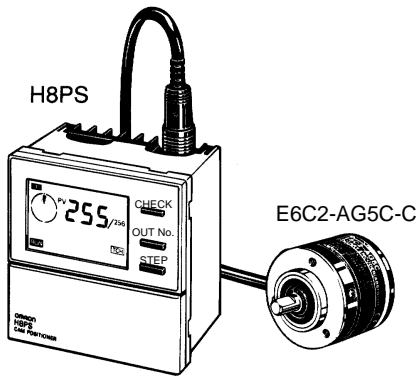

Model	Mounting method	Output configuration
H8PS-8B	Flush	NPN transistor output
H8PS-8BP		PNP transistor output
H8PS-8BF	Surface/Track	NPN transistor output
H8PS-8BFP		PNP transistor output

Specifications

Rated voltage	24 VDC
Cam resolution	1.4° (a resolution of 256 per rotation)
Outputs	Open-collector transistor output NPN: H8PS-8B(F) PNP: H8PS-8B(F)P  Cam outputs: 8 lines (Output No. 1 to 8) 30 VDC max., 100 mA max. (residual voltage: 2 V max.)  RUN OUT: Turns ON in Run and Test modes, OFF in Program mode in case of error 30 VDC max., 100 mA max. (residual voltage: 2 V max.)  TACHOMETER: 60-ppr signal output for rpm meter 30 VDC max., 30 mA max. (residual voltage: 0.5 V max. for NPN models, 2 V max. for PNP models)
Encoder response	330 rpm
Functions	Origin compensation (zero shift) Rotating direction selection Angle display selection Teaching

■ Connecting E6C2-AG5C to Programmable Controller

Example of Connection to CQM1-CPU44-E High-capacity CPU Unit with Absolute Interface and RS-232C Port

Position data can be directly input as 8, 10, or 12-bit gray code signals from Absolute Encoders to the CQM1-CPU44-E. The position data input is backed up during power failures. Therefore, the origin return operation is not required after the power supply resumes. Furthermore, the origin compensation function of the E6C2-AG5C makes it possible to use any position for the origin.

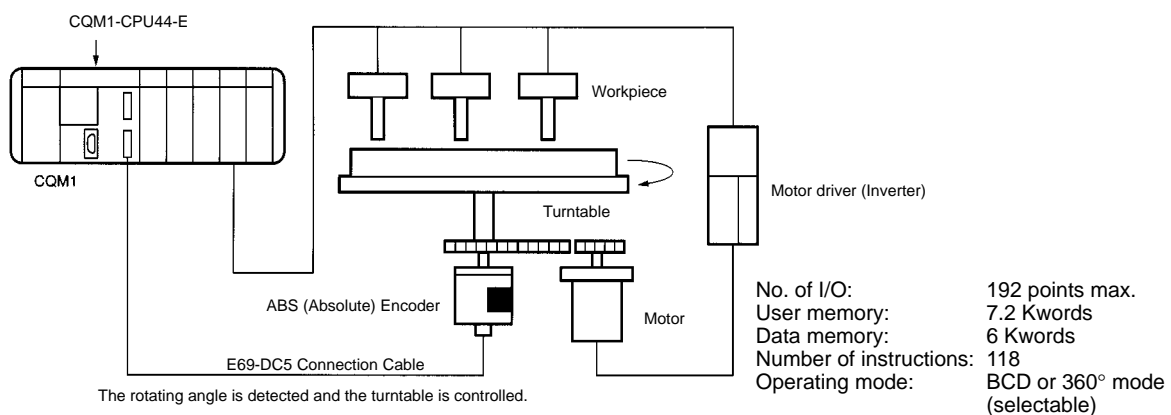

**Input Specifications**

<b>Input voltage</b>	24 VDC+10%/−15%
<b>Input impedance</b>	5.4 kΩ
<b>Input current</b>	4 mA (TYP.)
<b>ON voltage</b>	16.8 VDC min.
<b>OFF voltage</b>	3.0 VDC max.
<b>Counting speed</b>	4 kHz max.
<b>Input code</b>	Gray code (8, 10, or 12 bits)

**E69-DC5 5M Connection Cable for CQM1-CPU44-E (Order Separately)**

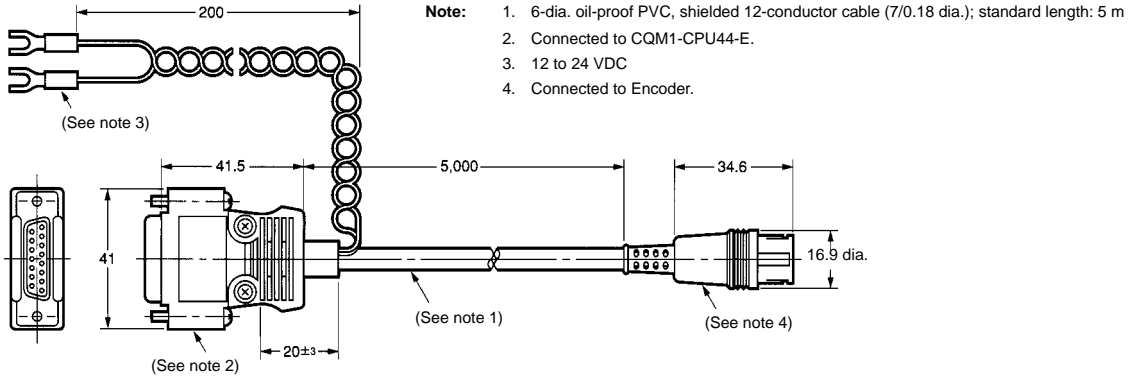

**System Configuration Using a Resolution of 1,024 per Rotation**

A combination of the CQM1-CPU44E and E6C2-AG5C ensures easy output angle setting for cam control in 360° or BCD mode.

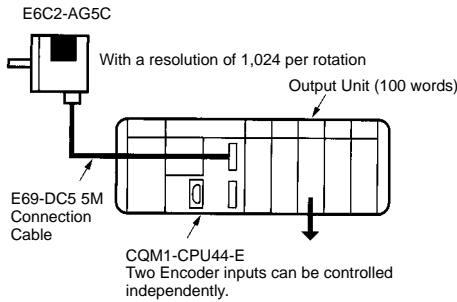

**Ladder Program Example**

Use the CTBL instruction of the CQM1-CPU44-E to register a maximum of eight comparison tables for output angle setting.

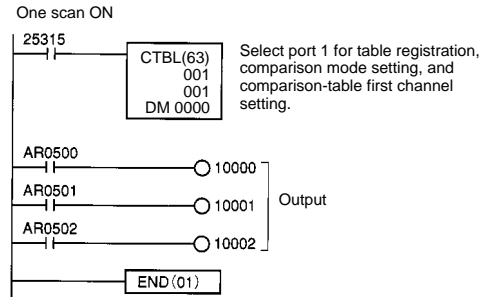

**Mode Setting of CQM1-CPU44-E**

Set port 1 to BCD mode and 10 bits

DM 6643 0001

**Output Timing**

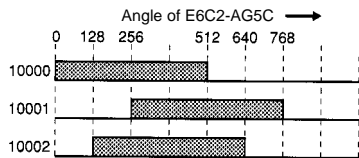

**Example of DM Setting for Comparison Table**

DM0000	0000	Lower limit 1	} Bit AR 0500
0001	0512	Upper limit 1	
0002	0000	Subroutine number 1	} Bit AR 0501
0003	0256	Lower limit 2	
0004	0768	Upper limit 2	} Bit AR 0502
0005	0000	Subroutine number 2	
0006	0128	Lower limit 3	} Bit AR 0502
0007	0640	Upper limit 3	
0008	0000	Subroutine number 3	} Not used.
0009	0000	Lower limit 4	
0022	0000	Upper limit 8	} Not used.
0023	0000	Subroutine number 8	

**Note:** An upper or lower limit can be set with integers in BCD mode and 5° increments in 360° mode. Subroutine numbers are set for interrupt processing.

**Internal Bits of CQM1-CPU44-E**

- Range Comparison Result

Each bit of the CQM1-CPU44-E CPU Unit's words AR 05 and AR 06 turns ON only when the comparison range coincides with the angle of E6C2-AG5C.

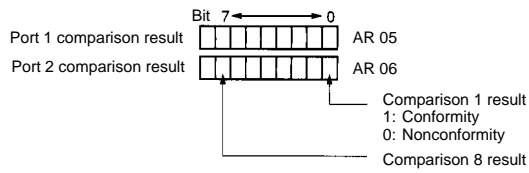

- Present Value Read

The gray code signals of the E6C2-AG5C are automatically converted into BCD or 360° code signals and read through the CQM1-CPU44-E CPU Unit's words AR 232 and AR 234. The present value can be used for ladder programs.

Port 1 angle \* \* \* \* Word 232  
 Port 2 angle \* \* \* \* Word 234

**Connecting to CPM1A Using a Resolution of 720 per Rotation**

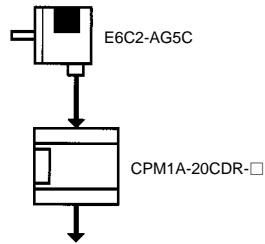

**Wiring Between E6C2-AG5C and CPM1A**

Output signal from E6C2-AG5C	Input signal to CPM1A
Brown (2 <sup>0</sup> )	00000
Orange (2 <sup>1</sup> )	00001
Yellow (2 <sup>2</sup> )	00002
Green (2 <sup>3</sup> )	00003
Blue (2 <sup>4</sup> )	00004
Purple (2 <sup>5</sup> )	00005
Gray (2 <sup>6</sup> )	00006
White (2 <sup>7</sup> )	00007
Pink (2 <sup>8</sup> )	00008
Light blue (2 <sup>9</sup> )	00009

**Ladder Program**

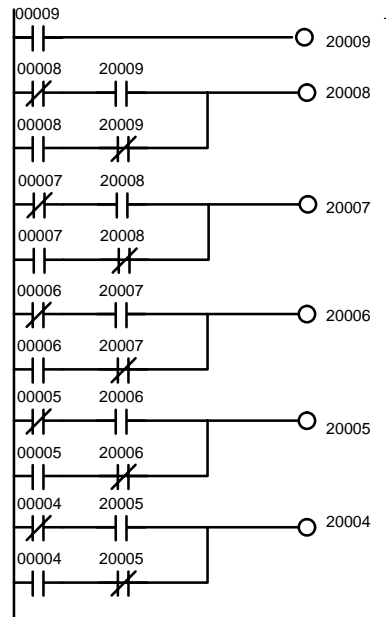

Converts a gray code signal into a BIN code signal (word 200).

**Output Timing**

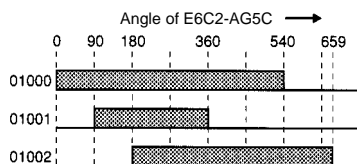

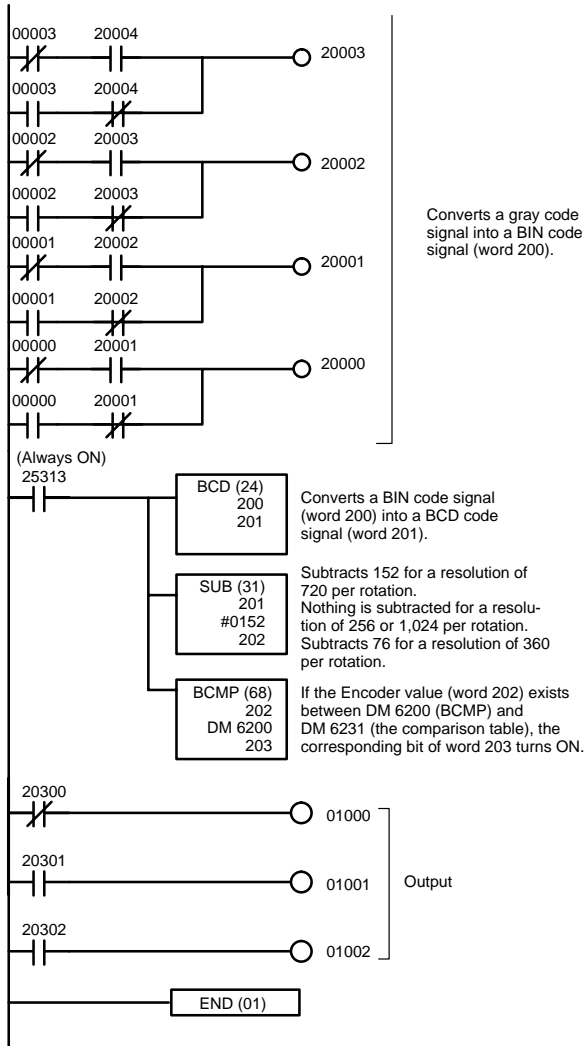

Example of DM Setting for Comparison Table

DM6200	0000	Lower limit 1	} Bit 20300
6201	0540	Upper limit 1	
6202	0090	Lower limit 2	} Bit 20301
6203	0360	Upper limit 2	
6204	0180	Lower limit 3	} Bit 20302
6205	0659	Upper limit 3	
6206	0000	Lower limit 4	} Not used.
6231	0000	Upper limit 16	

■ Gray-to-Binary Conversion Circuit Reference

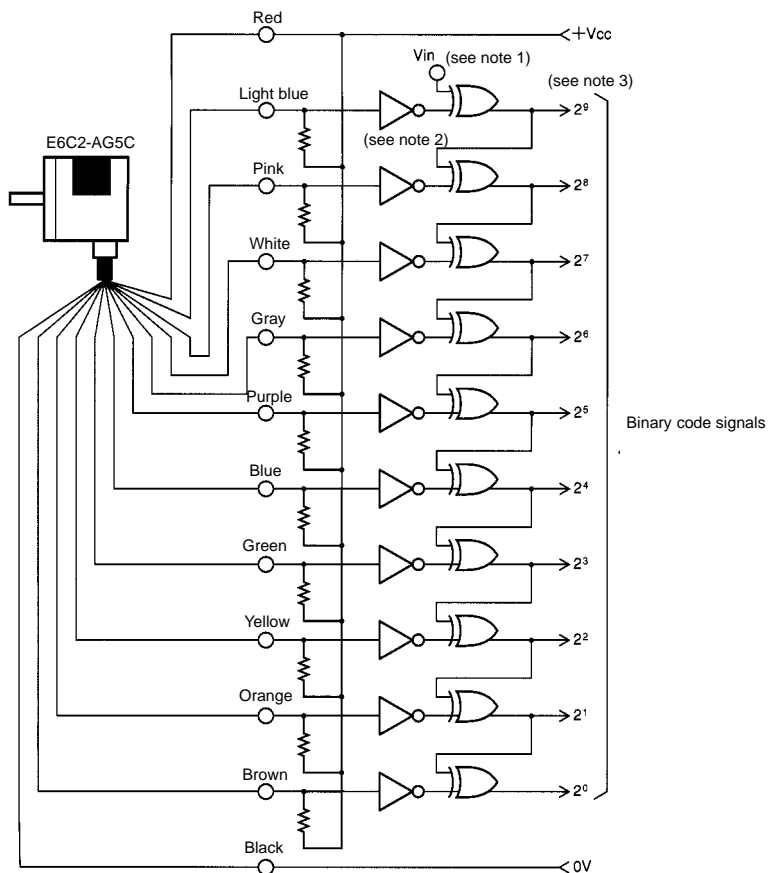

- Note:**
1. Signal can be converted into positive-logic binary code signals if 0 V is connected to Vin.
  2. Inverter
  3. Exclusive OR (EOR)

**Note:** The above circuit example is for 10-bit signals. For 9-bit signals, input Vin into the EOR of 2<sup>8</sup>, and for 8-bit signals, input Vin into the EOR of 2<sup>7</sup>.

Dimensions

**Note:** All units are in millimeters unless otherwise indicated.

E6C2-A□5□  
E6C2-AN□E

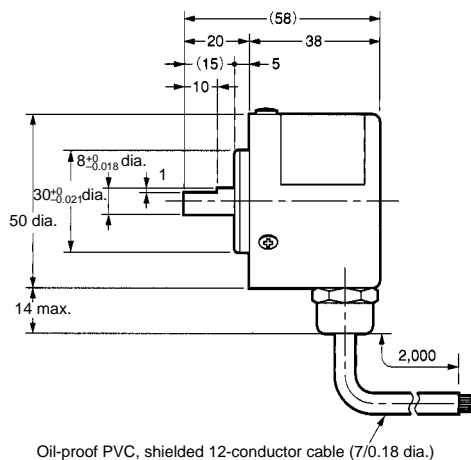
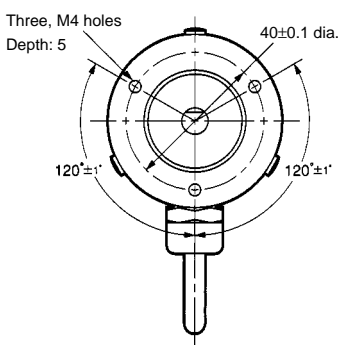
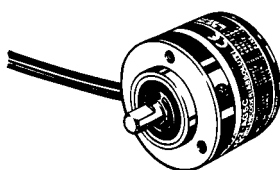

**Note:** E69-C08B Coupling is sold separately.

E6C2-AG5C-C

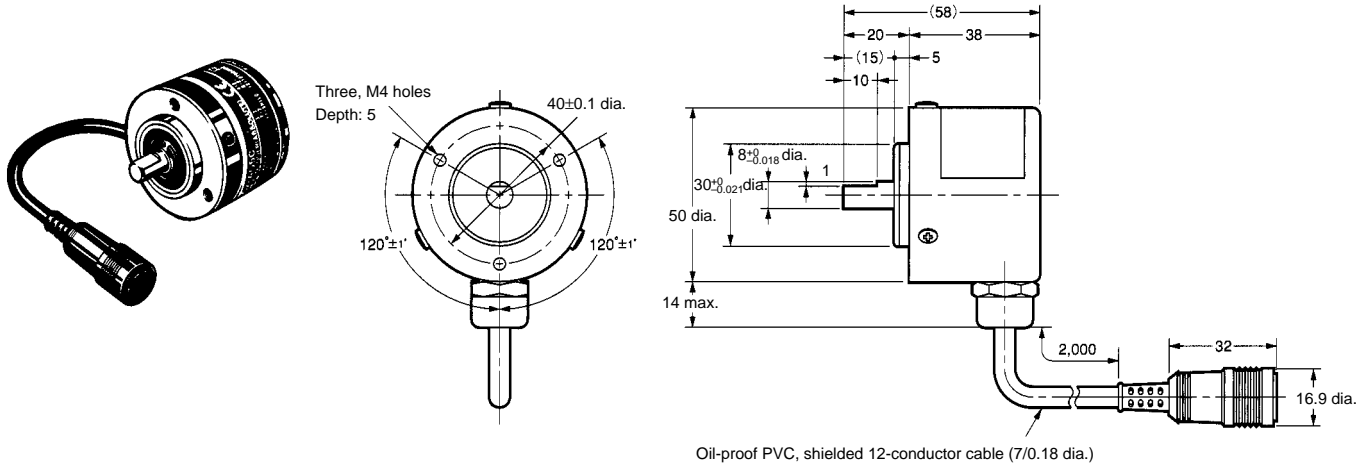

Note: E69-C08B is sold separately.

■ Accessories (Order Separately)

Flanges

E69-FCA03

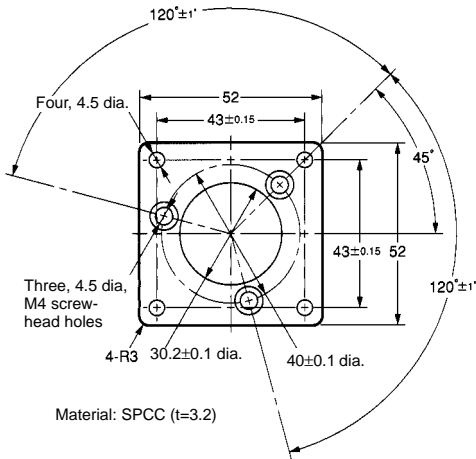

E69-FCA04

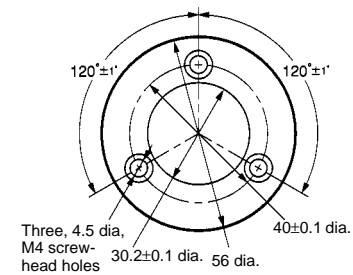

Mounting Bracket Installation

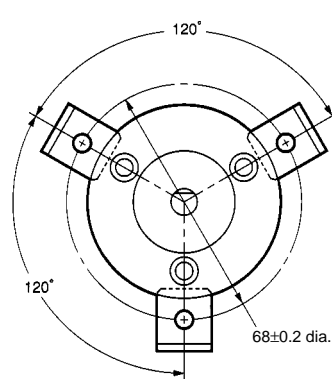

Mounting Brackets  
(Three Mounting Brackets Attached)

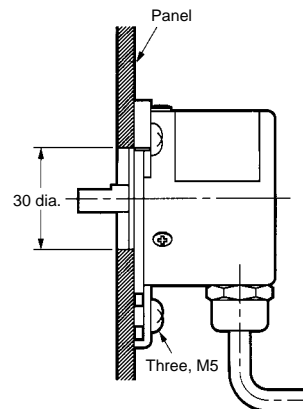
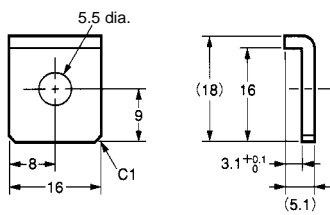

## Coupling

### E69-C08B

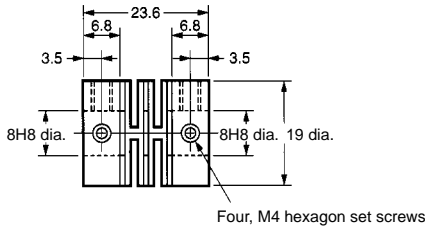

**Note:** Material: Glass-reinforced PBT

## Extension Cable

### E69-DF5

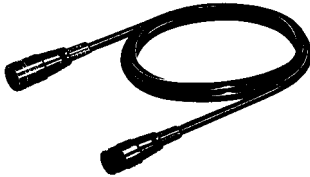

**Note:** The Cable can be extended up to 100 m for connecting the H8PS.

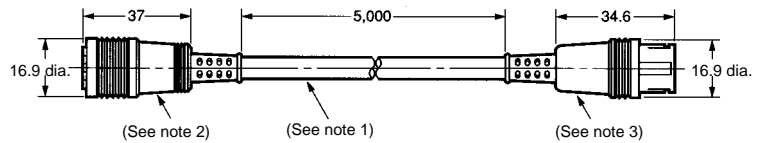

**Note:**

- 6-dia. oil-proof PVC, shielded 12-conductor cable (7/0.18 dia.); standard length: 5 m
- Connects to the H8PR Rotary Positioner and H8PS Cam Positioner.
- Connects to the connector of the E6C2-AG5C-C.

## Precautions

- The following actions may damage the E6C2-A.
  - Imposing a voltage which exceeds the rated voltage range.
  - Mistakes in wiring such as an error in power supply polarity.
  - Wiring while the E6C2-A is turned ON.
  - Load short-circuiting.
- Do not wire power lines or high-tension lines alongside the lines of the E6C2-A, otherwise the E6C2-A may be damaged or malfunction due to induction. Be sure to wire the lines of the E6C2-A separately from power lines or high-tension lines.

### Correct Use

- If the power supply has surge voltage, connect a surge suppressor between the positive and negative terminals of the power supply to absorb the surge voltage. Also, in order to protect the E6C2-A from noise as much as possible, shorten the wires connected to the E6C2-A as much as possible.
- Unnecessary pulses are output at the time the E6C2-A is turned ON or OFF. After turning ON the E6C2-A, be sure to wait 1 s before turning ON the peripheral devices connected to the E6C2-A 1 s and turn OFF the peripheral devices 0.1 s before turning OFF the E6C2-A.
- The E6C2-A consists of high-precision components and must be handled with utmost care.
  - Be sure that the E6C2-A is free of water or oil drops.
  - If the E6C2-A is mounted and wired with a cable, do not pull the cable with a force exceeding 29.4 N {3 kgf}.
  - The E6C2-A can be mounted with screws, in which case, be sure that the tightening torque applied to each screw does not exceed 0.49 N • m {5 kgf • cm}.
  - Do not impose excessive loads on the shaft, otherwise the shaft may break. The shaft may be coupled with a chain timing belt and gear only through a coupling and bearing.
  - If a significant installation error is made (misalignment), the shaft will be subjected to an excessive force that will damage the shaft.
  - When inserting the shaft into the coupling, do not use excessive force (by striking the coupling or shaft with a hammer, for example).
  - Do not impose excessive bending, pressure, or pulling force on the E6C2-A when inserting the shaft into the coupling or separating the coupling from the shaft.

**ALL DIMENSIONS SHOWN ARE IN MILLIMETERS.**

To convert millimeters into inches, multiply by 0.03937. To convert grams into ounces, multiply by 0.03527.

Cat. No. Q107-E1-2 **In the interest of product improvement, specifications are subject to change without notice.**

## **OMRON Corporation**

Industrial Sensors Division  
Sensing Devices and Components Division H.Q.  
28th Fl., Crystal Tower Bldg.,  
1-2-27, Shiromi, Chuo-ku,  
Osaka 540-6028 Japan  
Phone: (81)6-949-6012 Fax: (81)6-949-6021

Printed in Japan  
1298-1M (0697) (A)