

New General-purpose Incremental Rotary Encoder

- A wide operating voltage range of 5 to 24 VDC (open collector model).
- Resolution of 2,000 pulses/revolution in 40-mm housing.
- Phase Z can be adjusted with ease using the origin indicating function.
- A large load of 29.4 N (3 kgf) in the radial direction and 19.6 N (2 kgf) in the thrust direction is permitted.
- The load short-circuit and reversed connection protecting circuit assures highly reliable operation.
- A line driver output model is available. (Cable extends up to 100 m.)



Ordering Information

Supply voltage	Output configuration	Resolution (P/R)	Model
5 to 24 VDC	NPN open collector output	10/20/30/40/50/60/100/200/300/360/400/500/600/1,000/1,200/1,500/1,800/2,000	E6B2-CWZ6C
12 to 24 VDC	PNP open collector output	100/200/360/500/600/1,000/1,200/1,500/1,800/2,000	E6B2-CWZ5B
5 to 12 VDC	Voltage output	10/20/30/40/50/60/100/200/300/360/400/500/600/1,000/1,200/1,500/1,800/2,000	E6B2-CWZ3E
5 VDC	Line driver output		E6B2-CWZ1X

- Note:** 1. Pre-wired models are also available.
2. When ordering, specify the resolution together with the model number.

Accessories (Order Separately)

Name	Model
Coupling	E69-C06B (attachment)
	E69-C68B
	E69-C610B
	E69-C06M
Flange	E69-FBA
	E69-FBA02
Mounting Bracket	E69-2 (provided with the E69-FBA02)

Application Example

Filling Control

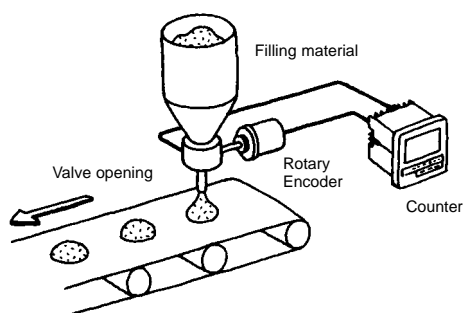

Specifications

■ Ratings/Characteristics

Electrical

Item	E6B2-CWZ6C	E6B2-CWZ5B	E6B2-CWZ3E	E6B2-CWZ1X
Power supply voltage	5 VDC -5% to 24 VDC +15%	12 VDC -10% to 24 VDC +15%	5 VDC -5% to 12 VDC +10%	5 VDC ±5%
Current consumption (see note 3)	80 mA max.	100 mA max.		160 mA max.
Resolution	10/20/30/40/50/60/100/200/300/360/400/500/600/1,000/1,200/1,500/1,800/2,000 P/R	100/200/360/500/600/1,000/2,000 P/R	10/20/30/40/50/60/100/200/300/360/400/500/600/1,000/1,200/1,500/1,800/2,000 P/R	
Output phases	A, B, and Z (reversible)			A, \bar{A} , B, \bar{B} , Z, \bar{Z}
Output configuration	Open collector	Open collector	Voltage	Line driver (see note 2)
Output capacity	30 VDC max. 35 mA max. Residual voltage: 0.4 V max.	35 mA max. Residual voltage: 0.4 V max.	20 mA max. Residual voltage: 0.4 V max.	AM26LS31 equivalent Output current: High level = $I_O = -20$ mA Low level = $I_S = 20$ mA Output voltage: High level = $V_O = 2.5$ V min. Low level = $V_S = 0.5$ V max.
Max. response frequency (see note 1)	100 kHz	50 kHz	100 kHz	
Phase difference on output	90°±45° between A and B (1/4T±1/8T)			
Rise and fall times of output	1 μs max. (control output voltage: 5 V; load resistance: 1 kΩ; cord length: 0.5 m)	1 μs max. (cord length: 2 m; I_{sink} : 10 mA max.)	1 μs max. (cord length: 0.5 m; I_{sink} : 10 mA max.)	0.1 μs max. (cord length: 0.5 m; I_O : -20 mA; I_S : 20 mA)
Insulation resistance	100 MΩ min. (at 500 VDC) between carry parts and case			
Dielectric strength	500 VAC, 50/60 Hz for 1 min between carry parts and case			

- Note:**
- The maximum electrical response revolution is determined by the resolution and maximum response frequency as follows:
Maximum electrical response frequency (rpm) = Maximum response frequency/resolution x 60
This means that the E6B2 Rotary Encoder will not operate electrically if its revolution exceeds the maximum electrical response revolution.
 - The line driver output is a data transmission circuit compatible with the RS-422A and long-distance transmission is possible with a twisted-pair cable.
 - An inrush current of approximately 9 A will flow for approximately 0.3 ms when the power is turned ON.

Mechanical

Item	E6B2-CWZ6C	E6B2-CWZ5B	E6B2-CWZ3E	E6B2-CWZ1X
Shaft loading	Radial: 29.4 N (3 kgf) Thrust: 19.6 N (2 kgf)			
Moment of inertia	$1 \times 10^{-6} \text{ kg} \cdot \text{m}^2$ (10 gf \cdot cm ²) max.; $3 \times 10^{-7} \text{ kg} \cdot \text{m}^2$ (3 gf \cdot cm ²) max. at 600 P/R max.			
Starting torque	980 $\mu\text{N} \cdot \text{m}$ (10 gf \cdot cm) max.			
Max. permissible revolution	6,000 rpm			
Vibration resistance	Destruction: 10 to 500 Hz, 150 m/s ² (15G) or 2-mm double amplitude for 11 min 3 times each in X, Y, and Z directions			
Shock resistance	Destruction: 1,000 m/s ² (100G) 3 times each in X, Y, and Z directions			
Weight	Approx. 100 g max. (cord length: 0.5 m)			

Environmental

Item	E6B2-CWZ6C	E6B2-CWZ5B	E6B2-CWZ3E	E6B2-CWZ1X
Ambient temperature	Operating: -10°C to 70°C (with no icing) Storage: -25°C to 85°C (with no icing)			
Ambient humidity	Operating: 35% to 85% (with no condensation)			
Degree of protection	IEC60529 IP50 (The E6B2 Rotary Encoder is not watertight or oil resistive.)			

Operation

■ Output Circuits

E6B2-CWZ6C

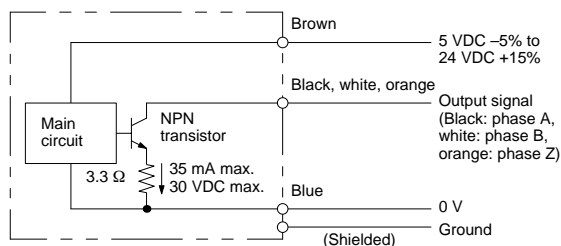

E6B2-CWZ5B

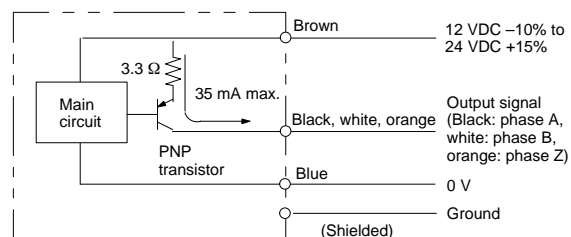

E6B2-CWZ3E

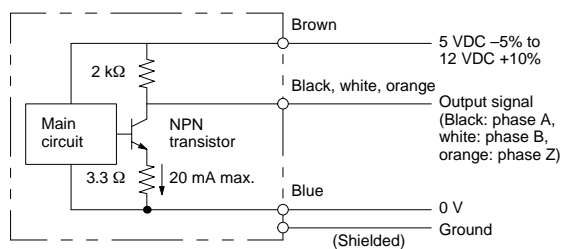

E6B2-CWZ1X

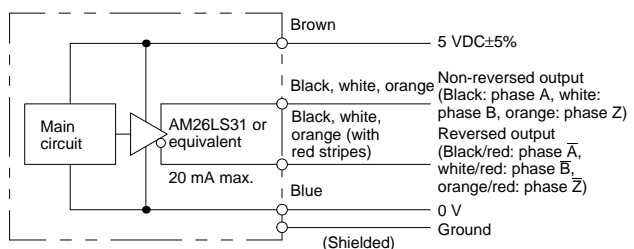

■ Timing Charts
Open Collector Output
E6B2-CWZ6C
E6B2-CWZ5B

Direction or resolution: CW
 (As viewed from the end of the shaft)

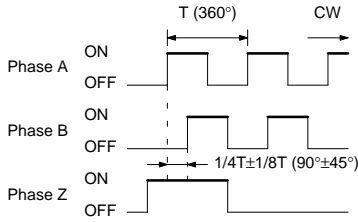

Note: Phase A is $1/4 \pm 1/8T$ faster than phase B. The ONs in the above timing chart mean that the output transistor is ON and the OFFs mean that the output transistor is OFF.

Direction or resolution: CCW
 (As viewed from the end of the shaft)

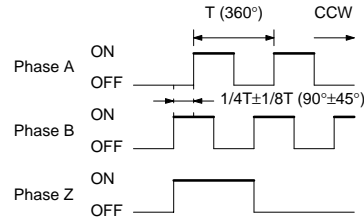

Note: Phase A is $1/4 \pm 1/8T$ slower than phase B.

Voltage Output
E6B2-CWZ3E

Direction or resolution: CW
 (As viewed from the end of the shaft)

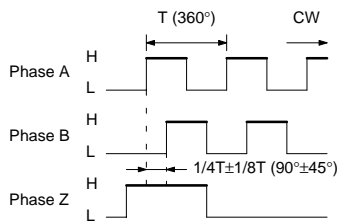

Note: Phase A is $1/4 \pm 1/8T$ faster than phase B.

Direction or resolution: CCW
 (As viewed from the end of the shaft)

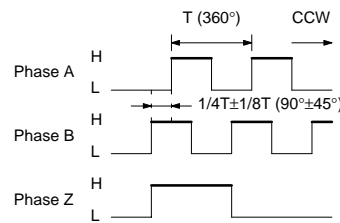

Note: Phase A is $1/4 \pm 1/8T$ slower than phase B.

Line Driver Output
E6B2-CWZ1X

Direction or resolution: CW
 (As viewed from the end of the shaft)

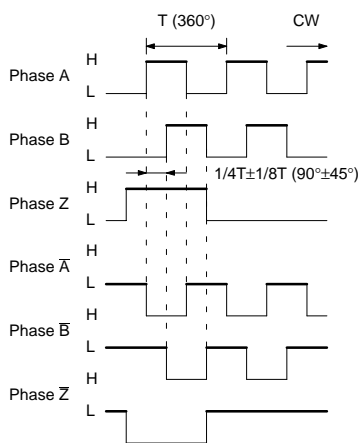

Note: The line driver output circuit is an RS-422A data transmission circuit consisting of two balanced output lines. The relationship between the two output lines is on an equal status. This means that if the level of the signal on a line is H, the level of the signal on the other line is L. The noise-resistive line driver output circuit assures high-speed data transmission.

Direction or resolution: CCW
 (As viewed from the end of the shaft)

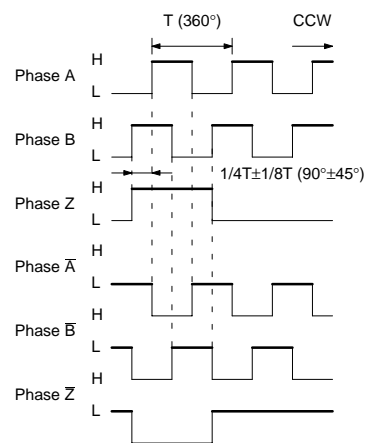

■ Input to More than One Counter from Encoder (with Voltage Output)

Use the following formula to obtain the number of counters to be connected to a single E6B2 Rotary Encoder.

$$\text{Number of counters (N)} = \frac{R1 (E-V)}{V \times R2}$$

E: Voltage supplied to Rotary Encoder
 V: Minimum input voltage of the counter
 R2: Output resistance of the Rotary Encoder
 R1: Input resistance of the counter

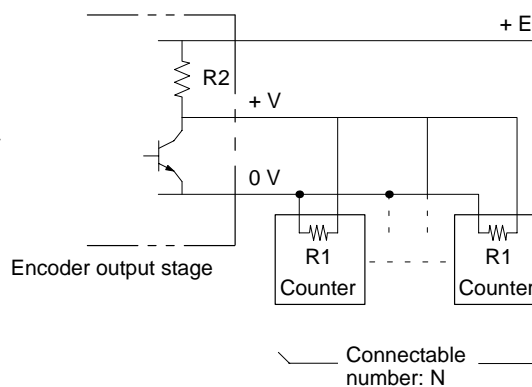

■ Origin Indication

It is easy to adjust the position of phase Z with the origin indication function. The following illustration (on the left-hand side) shows the relationship between phase Z and the origin. Set cut face D to the origin as shown in the illustration (on the right-hand side).

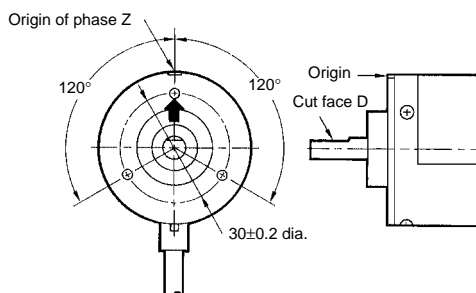

■ Output Protection Circuit

The E6B2 (open collector model with voltage output) incorporates a circuit preventing the E6B2 from damage due to a short-circuited load and reversed connection.

Dimensions

Note: All units are in millimeters unless otherwise indicated.

E6B2

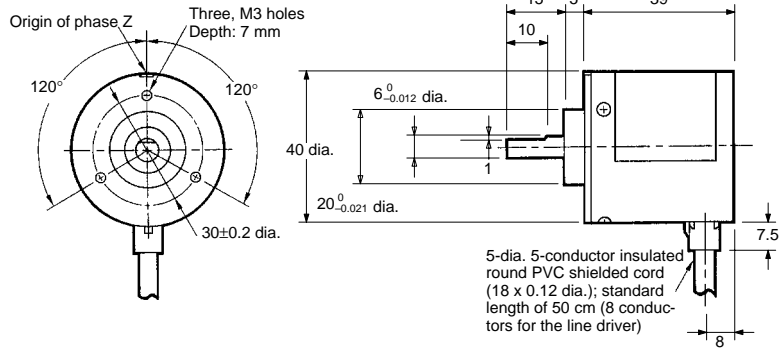
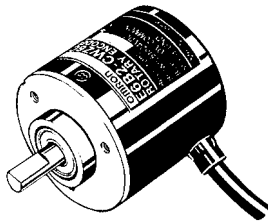

**Coupling
E69-C06B
(Included)**

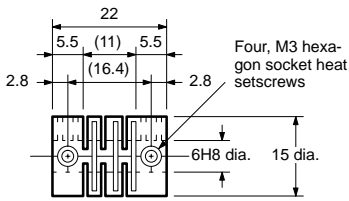

**E69-C68B
(Sold Separately, Different Diameter)**

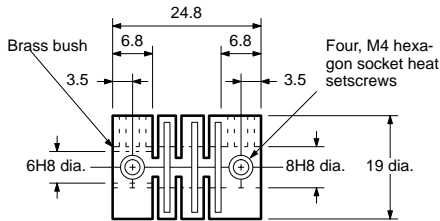

**E69-C610B
(Sold Separately, Different Diameter)**

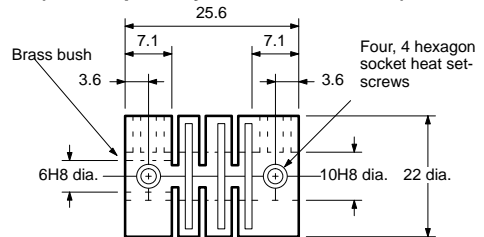

Note: The coupling is made of glass-reinforced PBT.

**E69-C06M
(Sold Separately, Different Diameter)**

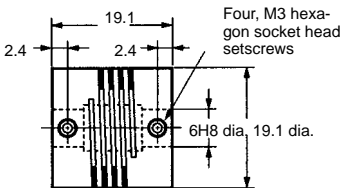

Note: The coupling is made of super super duralumin.

Flange (Sold Separately)

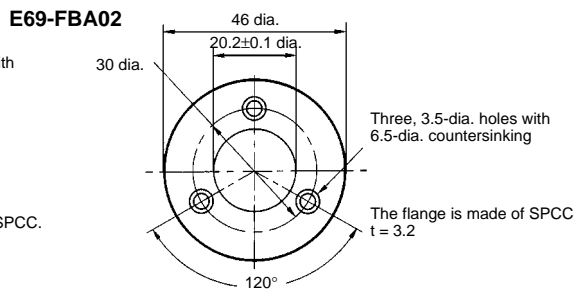
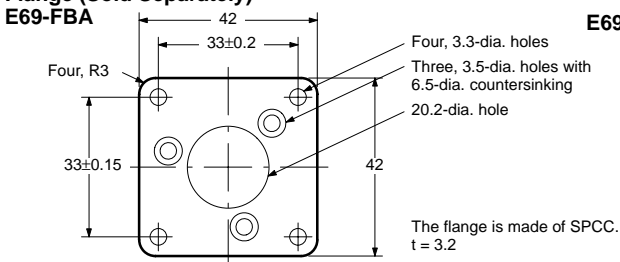

**Mounting Bracket (Three Pieces as a Set)
E69-2 (One Set Provided with the E69-FBA02)**

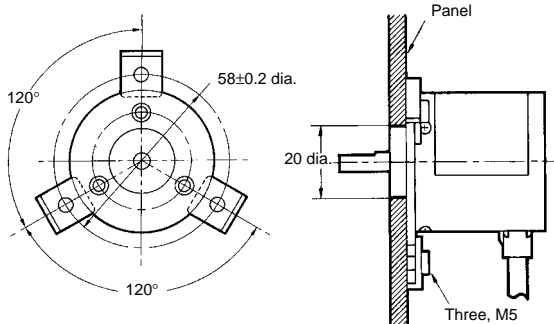
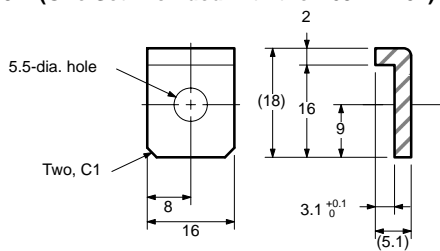

Installation

■ Connection

Be sure to connect the external terminals correctly or the E6B2 Rotary Encoder may be damaged.

E6B2-CWZ6C/-CWZ5B/-CWZ3E

Color	Terminal
Brown	Power supply (+V _{CC})
Black	Output phase A
White	Output phase B
Orange	Output phase Z
Blue	0 V (common)

E6B2-CWZ1X

Color	Terminal
Brown	Power supply (+V _{CC})
Black	Output phase A
White	Output phase B
Orange	Output phase Z
Black/red stripes	Output phase \bar{A}
White/red stripes	Output phase \bar{B}
Orange/red stripes	Output phase \bar{Z}
Blue	0 V (common)

Note: Receiver: AM26LS32 equivalent

- Note:**
1. The external conductor (shield) of the shielded cord is not connected to the internal conductors nor to the case.
 2. All the phases A, B, and Z are in the same circuit.
 3. Connect the GND to the 0-V line or to the ground terminal.

■ Conversion from E6B to E6B2

Refer to the following table for conversion from the E6B to the E6B2.

E6B	E6B2
Resolution: 10 to 600 P/R	Resolution: 10 to 2,000 P/R
E6B-CWZ3C	E6B2-CWZ6C
E6B-CWZ3E	E6B2-CWZ3E
---	E6B2-CWZ1X (line driver output)

■ Connections with Peripheral Devices

Coupling	Specification	Resin, standard type				Resin, non-standard opening diameter		Metal	
		4 (H8), 13	6 (H8), 15	8 (H8), 19	10 (H8), 22	6/8 (H8), 19	6/10 (H8), 22	6 (H8), 19.1	10 (H8), 25.4
Rotary Encoder	Model	E69-C04B	E69-C06B	E69-C08B	E69-C10B	E69-C68B	E69-C610B	E69-C06M	E69-C10M
E6B2, 6 mm diameter		C	A	C	C	B	B	B	C

- Note:**
- A: Possible to connect directly in most cases.
 - B: Possible to connect, but an independent power supply or pull-up resistor will be required.
 - C: Impossible to connect.

Connection Examples

Connection to H7CR-CW Counter

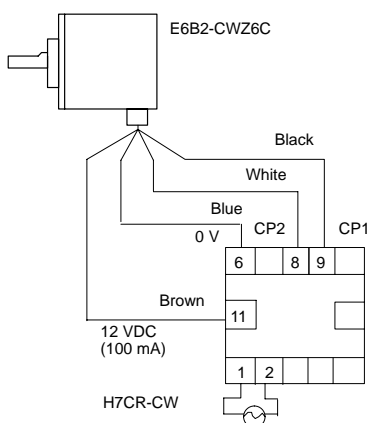

Features of H7CR

DIN-sized (DIN 48) counter incorporating a prescale function converting the measured value to the actual value.

Synchronized output and \pm indication are available (\pm area models).

Models with a general-purpose six-digit display and four-digit display are available.

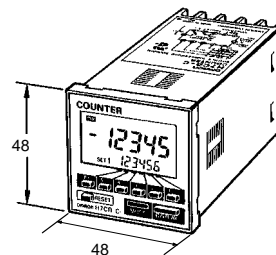

Connection to K3NR-NB□□□/K3NP-NB□□□ Rotary Intelligent Signal Processor

Features of K3NR/K3NP

Each model incorporates a prescale function with an input range of 50 kHz and the measurement accuracy is 0.006%.

A variety of outputs including relay, transistor, BCD, linear, and communications outputs are available.

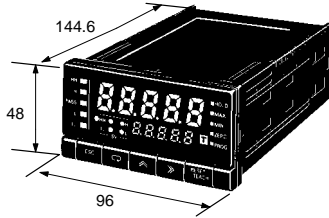

Precautions

■ Mounting Mounting Procedure

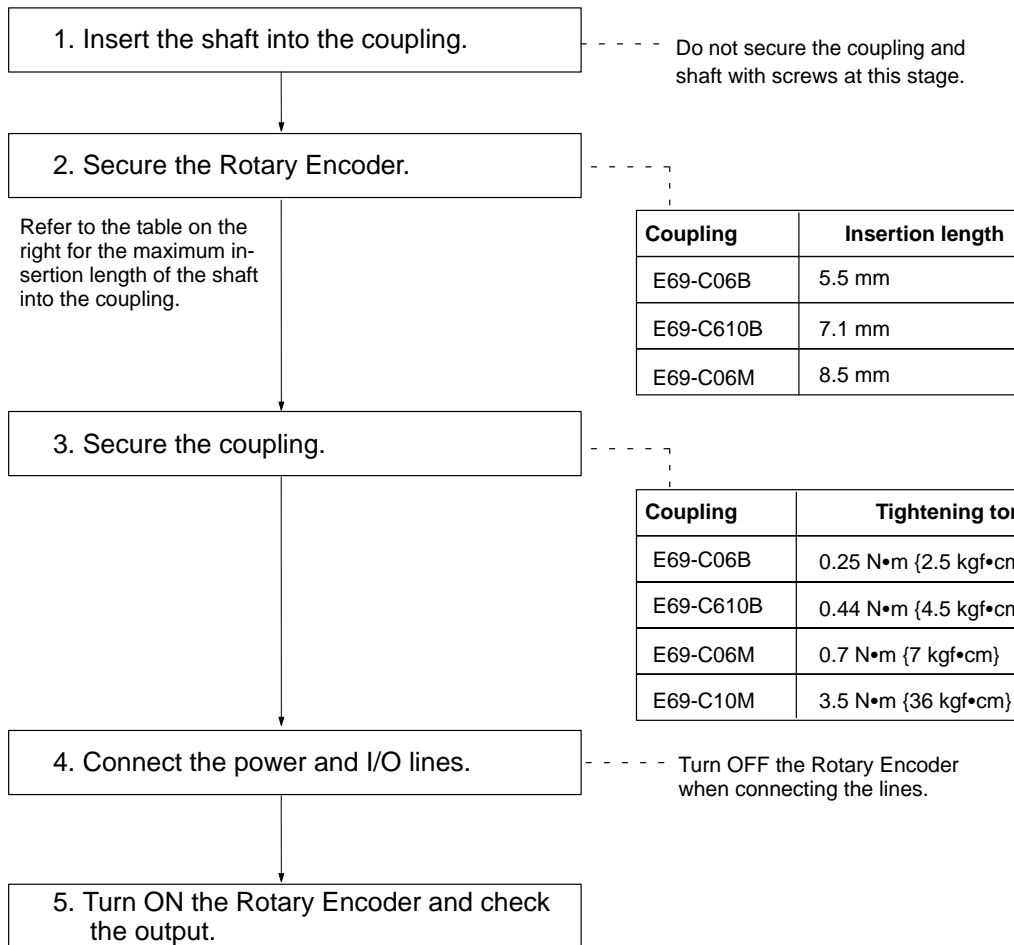

Installation

Be careful not to spray water or oil onto the E6B2 Rotary Encoder. The E6B2 Rotary Encoder consists of high-precision components. Handle it with utmost care and do not drop the Rotary Encoder, otherwise malfunctioning may result.

When the E6B2 Rotary Encoder is used in reversing operation, pay utmost attention to the mounting direction of the E6B2 Rotary Encoder and the directions of increment and decrement rotation.

To match phase Z of the E6B2 Rotary Encoder and the origin of the device to be connected to the E6B2 Rotary Encoder, conform the phase Z output when connecting the device.

Do not impose an excessive load on the shaft if the shaft is connected to a gear.

If the Rotary Encoder is mounted with screws, the tightening torque must be approximately 0.49 N•m (5kgf•cm).

Refer to the following illustrations when using a standard coupling.

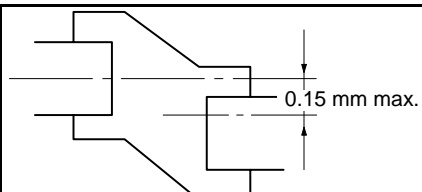
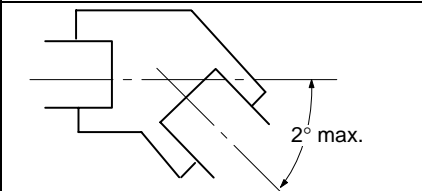
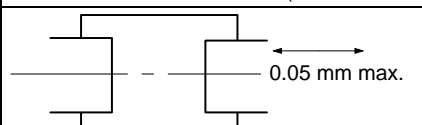
Eccentricity tolerance	
Declination tolerance	
Displacement tolerance in the shaft direction	

If the eccentricity or declination value exceeds the tolerance, an excessive load imposed on the shaft may damage the Rotary Encoder or shorten the life of the Rotary Encoder.

Mounting

When connecting the shaft of the Rotary Encoder with a chain timing belt or gear, connect the chain timing belt or gear with the shaft via the bearing and coupling as shown in the following illustration.

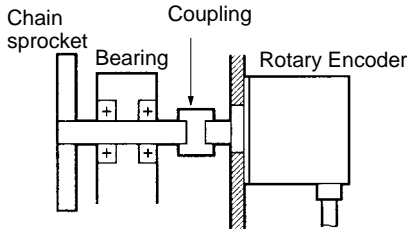

Do not hit the shaft or coupling with a hammer when inserting the shaft into the coupling. No shock must be applied to the shaft or coupling.

When connecting or disconnecting the coupling, do not bend, press, or pull the coupling excessively.

Bearing Life

The following graph shows the life expectancy values (theoretical values) of the bearings with the radial and thrust loads imposed on the bearings.

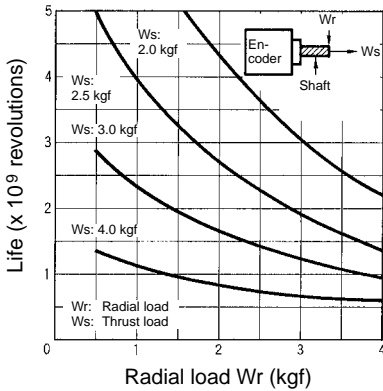

Wiring

If the Rotary Encoder is mounted in a panel, do not pull the cord with more than a force of 29.4 N (3 kgf).

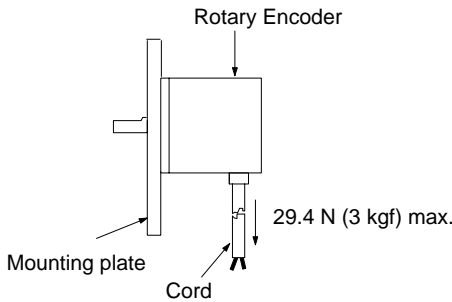

Do not pull the cord of the E6B2 rotary Encoder after the E6B2 Rotary Encoder is mounted to a panel. Do not apply any shock to the hollow shaft or the body.

Connections

When extending the cord, select the kind of cord with care, taking the response frequency into consideration. The longer the cord is, the more the residual voltage increases due to the resistance of the cord and the capacitance between the wires. As a result, the waveform will be distorted.

OMRON recommends models with a line driver output if the cord needs to be extended.

To reduce inductive noise, the cord must be laid the shortest distance, especially when the signal is input to an IC.

Insert a surge absorber between the power supply terminals if there is any surge.

To reduce noise, the total cord length must be as short as possible. Incorrect pulses may be generated when the E6B2 Rotary Encoder is turned ON or OFF. Do not use the connected device for 0.1 s after the E6B2 Rotary Encoder is turned ON and for 0.1 s before the E6B2 Rotary Encoder is turned OFF.

Cord Extension

The rise time of each output waveform will increase when the cord is extended. This will affect the phase difference characteristics of phases A and B.

The rise time varies with the resistance of the cord, the kind of cord, and the length of the cord.

The residual output voltage will increase according to the length of the cord.

E6C2-CWZ6C

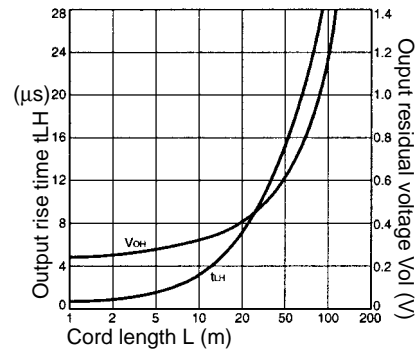

Measurement example

Power supply voltage: 5 VDC

Load resistance: 1 kΩ

(Residual output voltage was measured at a load current of 35 mA.)

Cord: Dedicated cord

Preventing Miscounting

If the operation of the E6B2 Rotary Encoder is stopped near a signal rising or falling edge, incorrect pulses may be generated, in which case the E6B2 Rotary Encoder will miscount. Use an increment-decrement counter to prevent miscounting.

Extension of Line Driver Output

Use twisted-pair cable to extend the line driver cord.

Recommended cable: Tachii Densen's TKVVBS4P-02A

Use an RS-422A receiver.

The twisted-pair wires shown in the following illustration are suitable for RS-422A signal transmission. Normal mode noise can be eliminated by twisting the wires because the generated electrical forces on the lines cancel each other.

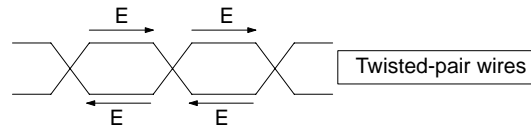

Check that the E6B2 is supplied with 5 VDC when a line driver output is used. There will be an approximately 1 V voltage drop if the cable length is 100 m.

■ Others

Input to More than One Counter from Rotary Encoder (with Voltage Output)

Use the following formula to obtain the number of counters to be connected to a single E6B2 Rotary Encoder.

$$\text{Number of counters (N)} = \frac{R1(E-V)}{V \cdot R2}$$

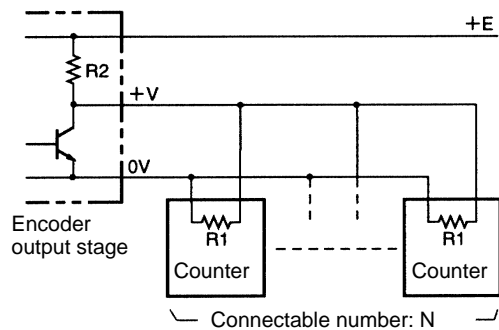

- E: Voltage supplied to Rotary Encoder
- V: Minimum input voltage of the counter
- R1: Input resistance of the Rotary Encoder
- R2: Output resistance of the Rotary Encoder

The product has been produced at OMRON Ayabe which obtained ISO9001-approval for its quality system and ISO14001-approval for its environmental management system from international certification bodies.

ALL DIMENSIONS SHOWN ARE IN MILLIMETERS.

To convert millimeters into inches, multiply by 0.03937. To convert grams into ounces, multiply by 0.03527.

Cat. No. Q085-E1-1C **In the interest of product improvement, specifications are subject to change without notice.**

OMRON Corporation

Industrial Automation Company

Industrial Sensors Division
Sensing Devices and Components Division H.Q.
28th Fl., Crystal Tower Bldg.,
1-2-27, Shiromi, Chuo-ku,
Osaka 540-6028 Japan
Tel: (81)6-6949-6012/Fax: (81)6-6949-6021

Printed in Japan
0100-0.3M (1092) Ⓐ