

Incremental Rotary Encoder

E6C2-C

IP64 Drip-proof Construction (IP65f for E6C2-C□H)

The E6C2-C incorporates a rubber-seal bearing cover of IP64 drip-proof construction thus ensuring ease of use in places with water dripping or sprayed oil.



E6C2-C



E6C2-C□H



Shaft Withstands Heavy Loads

The bearing used by the E6C2-C is larger than that of the conventional E6C-C, thus withstanding heavier loads.

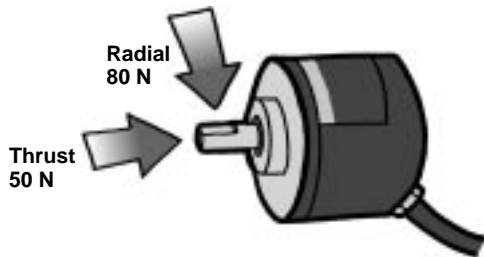

Note: Radial and thrust for the E6C2-C□ are 50 N and 30 N respectively.

Protective Circuit for Output Shorting

The E6C2-C incorporates a circuit protecting the E6C2-C from damage resulting from the incorrect wiring of output, thus ensuring ease of use.

33% Smaller than E6C-C

The E6C2-C uses a high-performance LED indicator, custom-made receiver element, high-density PCB, and seal bearing thus making the E6C2-C 33% smaller than the conventional E6C-C.

Conventional Model



E6C-C
50 dia. x 60 mm



E6C2-C
50 dia. x 40 mm

New



E6C2-C□H
50 dia. x 38 mm

Incorporating Cord to Be Pulled Out Aslant Ensuring Ease of Mounting and Wiring

To suit the mounting position, it was necessary to select a conventional E6C-C model with a cord that is pulled out horizontally or a model with a cord that is pulled out backwards. The E6C2-C incorporates a cord that is pulled out aslant, thus ensuring ease of mounting and wiring while saving mounting space.

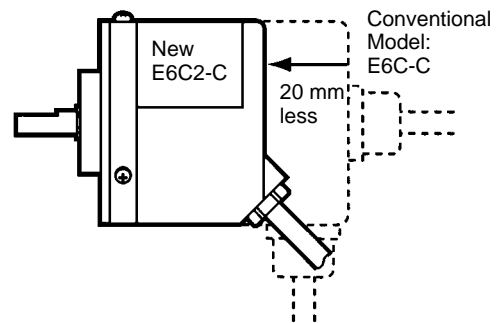

Ordering Information

Item	Supply voltage	Output configuration	Resolution (P/R)	Model
Standard models	5 to 24 VDC	NPN open collector output	10, 20, 30, 40, 50, 60, 100, 200, 300, 360, 400, 500, 600	E6C2-CWZ6C
			720, 800, 1,000, 1,024, 1,200, 1,500, 1,800, 2,000	
	12 to 24 VDC	PNP open collector output	100, 200, 360, 500, 600	E6C2-CWZ5B
			1,000, 2,000	
	5 to 12 VDC	Voltage output	10, 20, 30, 40, 50, 60, 100, 200, 300, 360, 400, 500, 600	E6C2-CWZ3E
			720, 800, 1,000, 1,024, 1,200, 1,500, 1,800, 2,000	
	5 VDC	Line driver output	10, 20, 30, 40, 50, 60, 100, 200, 300, 360, 400, 500, 600	E6C2-CWZ1X
			720, 800, 1,000, 1,024, 1,200, 1,500, 1,800, 2,000	
Solid 8-dia. shaft models	12 to 24 VDC	Complimentary output	100, 200	E6C2-CWZ5GH
			300, 360, 500, 600, 720, 800, 1,000, 1,024, 1,200, 1,500, 1,800, 2,000, 2,048, 2,500, 3,600	
	5 to 12 VDC	Voltage output	100, 200	E6C2-CWZ3EH
			300, 360, 500, 600, 720, 800, 1,000, 1,024, 1,200, 1,500, 1,800, 2,000, 2,048, 2,500, 3,600	
	5 to 12 VDC	Line driver output	100, 200	E6C2-CWZ3XH
			300, 360, 500, 600, 720, 800, 1,000, 1,024, 1,200, 1,500, 1,800, 2,000, 2,048, 2,500, 3,600	

Note: When ordering, specify the resolution in addition to the model numbers.

■ Accessories (Order Separately)

Name	Model	Applicable Rotary Encoders	Remarks
Coupling	E69-C06B	E6C2-CWZ□	---
	E69-C68B		Incorporates ends different to each other in diameter.
	E69-C06M		Metal construction.
	E69-C08B	E6C2-CWZ□H	---
Flange	E69-FCA	E6C2-CWZ□	
	E69-FCA02		
	E69-FCA03	E6C2-CWZ□H	
	E69-FCA04		
Servo Mounting Bracket	E69-2	---	Provided with the E69-FCA02 Flange.

Application Examples

Filler Control

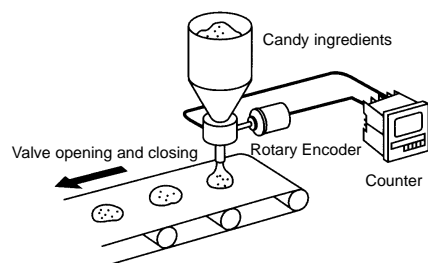

Positioning of Wafer Cutting Machine

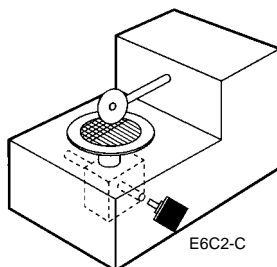

Metal Mold Positioning of Injection Molding Machine

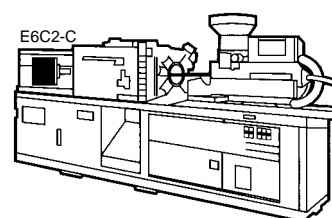

Specifications

■ Ratings/Characteristics

Standard Models

Item	E6C2-CWZ6C	E6C2-CWZ5B	E6C2-CWZ3E	E6C2-CWZ1X
Power supply voltage	5 VDC -5% to 24 VDC +15%	12 VDC -10% to 24 VDC +15%	5 VDC -5% to 12 VDC +10%	5 VDC±5%
Current consumption (see note 1)	80 mA max.	100 mA max.		160 mA max.
Resolution	10, 20, 30, 40, 50, 60, 100, 200, 300, 360, 400, 500, 600, 720, 800, 1,000, 1,024, 1,200, 1,500, 1,800, 2,000 P/R	100, 200, 360, 500, 600, 1,000, 2,000 P/R	10, 20, 30, 40, 50, 60, 100, 200, 300, 360, 400, 500, 600, 720, 800, 1,000, 1,024, 1,200, 1,500, 1,800, 2,000 P/R	
Output phases	A, B, and Z (reversible)			A, \bar{A} , B, \bar{B} , Z, \bar{Z}
Output configuration	NPN open collector output	PNP open collector output	Voltage output (NPN output)	Line driver output (see note 2)
Output capacity	Applied voltage: 30 VDC max. Output current: 35 mA max. Residual voltage: 0.4 V max. (at sink current of 35 mA)	Output current: 35 mA max. Residual voltage: 0.4 V max. (at sink current of 35 mA)	Output resistance: 2 kΩ Output current: 20 mA max. Residual voltage: 0.4 V max. (at sink current of 20 mA)	AM26LS31 equivalent Output current: High level (I_o): -20 mA Low level (I_s): 20 mA Output voltage: V_o : 2.5 V min. V_s : 0.5 V max.
Max. response frequency (see note 3)	100 kHz	50 kHz	100 kHz	
Phase difference on output	90°±45° between A and B (1/4T±1/8T)			
Rise and fall times of output	1 μs max. (control output voltage: 5 V; load resistance: 1 kΩ; cable length: 2 m)	1 μs max. (cable length: 2 m; I_{sink} : 10 mA)		0.1 μs max. (cable length: 2 m; I_o : -20 mA; I_s : 20 mA)
Starting torque	10 m N • m max.			
Moment of inertia	1 x 10 ⁻⁶ kg • m ² max.; 3 x 10 ⁻⁷ kg • m ² max. at 600 P/R max.			
Shaft loading	Radial: 50 N Thrust: 30 N			
Max. permissible revolution	6,000 rpm			
Protection circuits	Reversed power supply connection protection circuit, output load short-circuit protection circuit			---
Ambient temperature	Operating: -10°C to 70°C (with no icing) Storage: -25°C to 85°C (with no icing)			
Ambient humidity	Operating: 35% to 85% (with no condensation)			
Insulation resistance	20 MΩ min. (at 500 VDC) between current carry parts and case			
Dielectric strength	500 VAC, 50/60 Hz for 1 min between current carry parts and case			
Vibration resistance	Destruction: 10 to 500 Hz, 150 m/s ² or 2-mm double amplitude for 11 min 3 times each in X, Y, and Z directions			
Shock resistance	Destruction: 1,000 m/s ² (100G) 3 times each in X, Y, and Z directions			
Degree of protection	IEC60529 IP64			
Connection method	Pre-wired (standard length: 2 m)			
Weight	Approx. 400 g			
Others	Instruction manual			

- Note:**
1. An inrush current of approx. 9 A flows for approx. 0.3 ms right after the E6C2-C is turned on.
 2. The line driver output of the E6C2-C is used for data transmission circuitry conforming to RS-422A and ensures long-distance transmission over twisted-pair cable, the quality of which is equivalent to AM26LS31.
 3. The maximum electrical response revolution is determined by the resolution and maximum response frequency as follows:
Maximum electrical response frequency (rpm) = Maximum response frequency/resolution x 60
This means that the E6C2-C Rotary Encoder will not operate electrically if its revolution exceeds the maximum electrical response revolution.
 4. **Origin Indication**
It is easy to adjust the position of phase Z with the origin indication function. The following illustration (on the left side) shows the relationship between phase Z and the origin. Set cut face D to the origin as shown in the illustration (on the right side).

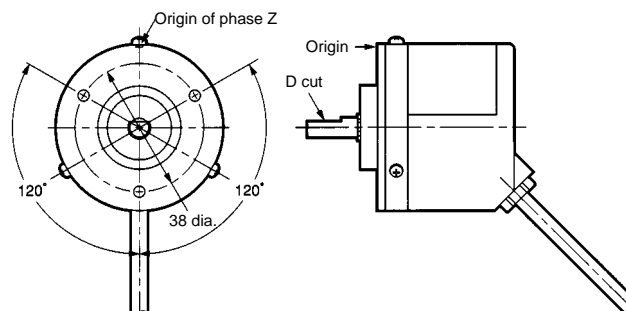

Solid 8-dia. Shaft Models

Item	E6C2-CWZ5GH	E6C2-CWZ3EH	E6C2-CWZ3XH
Power supply voltage	12 VDC -10% to 24 VDC +15%	5 VDC -5% to 12 VDC +10%	
Current consumption (see note 1)	100 mA max.		
Resolution	100, 200, 300, 360, 500, 600, 720, 800, 1,000, 1,024, 1,200, 1,500, 1,800, 2,000, 2,048, 2,500, 3,600 P/R		
Output phases	A, B, and Z (reversible)		A, \bar{A} , B, \bar{B} , Z, \bar{Z}
Output configuration	Complementary output (see note 5)	Voltage output (NPN output)	Line driver output (see note 2)
Output capacity	Output voltage: V _H =V _{cc} - 3 V min. (I _o =30 mA) V _L =2 V max. (I _o =-30 mA) Output current: ±30 mA	Output resistance: 1 kΩ Output current: 35 mA max. Residual voltage: 0.7 V max.	AM26LS31 equivalent Output current: High level (I _o): 10 mA Low level (I _s): -10 mA Output voltage: V _o : 2.5 V min. V _s : 0.5 V max.
Max. response frequency (see note 3)	125 kHz		
Phase difference on output	90°±45° between A and B (1/4T±1/8T)		
Rise and fall times of output	1 μs max. (cable length: 2 m, output current: 30 mA)	1 μs max. (cable length: 2 m, output current: 35 mA)	1 μs max. (cable length: 2 m, I _o =-10 mA, I _s =10 mA)
Starting torque	At normal temperature: 10 m N • m max., at low temperature: 15 m N • m max.		
Moment of inertia	1.8 x 10 ⁻⁶ kg • m ² max.; 1.5 x 10 ⁻⁶ kg • m ² max. at 200 P/R max.		
Shaft loading	Radial: 80 N Thrust: 50 N		
Max. permissible revolution	5,000 rpm		
Protection circuits	Reversed power supply connection protection circuit, output load short-circuit protection circuit	---	
Ambient temperature	Operating: -10°C to 70°C (with no icing) Storage: -25°C to 85°C (with no icing)		
Ambient humidity	Operating: 35% to 85% (with no condensation)		
Insulation resistance	20 MΩ min. (at 500 VDC) between current carry parts and case		
Dielectric strength	500 VAC, 50/60 Hz for 1 min between current carry parts and case		
Vibration resistance	Destruction: 10 to 500 Hz, 150 m/s ² or 2-mm double amplitude for 11 min 3 times each in X, Y, and Z directions		
Shock resistance	Destruction: 1,000 m/s ² 3 times each in X, Y, and Z directions		
Degree of protection	IEC60529 IP65		
Connection method	Pre-wired (standard length: 2 m)		
Weight	Approx. 400 g		
Others	Instruction manual		

- Note:**
1. An inrush current of approx. 6 A flows for approx. 0.1 ms right after the E6C2-C is turned on.
 2. The line driver output of the E6C2-C is used for data transmission circuitry conforming to RS-422A and ensures long-distance transmission over twisted-pair cable, the quality of which is equivalent to AM26LS31.
 3. The maximum electrical response revolution is determined by the resolution and maximum response frequency as follows:
Maximum electrical response frequency (rpm) = Maximum response frequency/resolution x 60
This means that the E6C2-C Rotary Encoder will not operate electrically if its revolution exceeds the maximum electrical response revolution.
 4. Complementary Output:
The complementary output has two output transistors (NPN and PNP) as shown below.
These two output transistors alternately turn ON and OFF depending on the "H" or "L" output signal. When using them, pull up to the positive power or pull down to 0 V.
The complementary output allows flow-in or flow-out of the output current and thus the rising and falling speeds of signals are fast. This allows a long cable distance.
They can be connected to open-collector input devices (NPN, PNP). They can also be connected to voltage input devices. It is recommended that the E6C2-CWZ3EH (voltage output models) be used for voltage input devices in order to ensure their original performance rating.

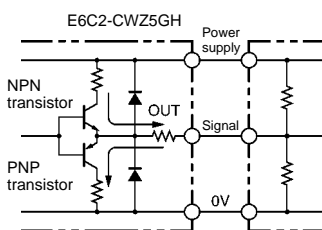

Output Signal Rise/Fall Time

Complementary Output

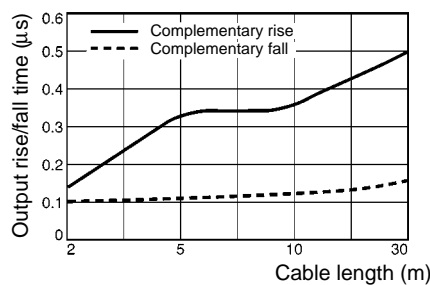

Voltage Output

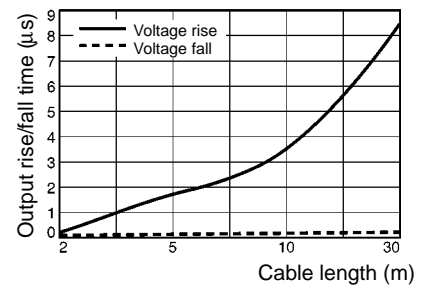

Operation

Output Circuit Diagram

E6C2-CWZ6C

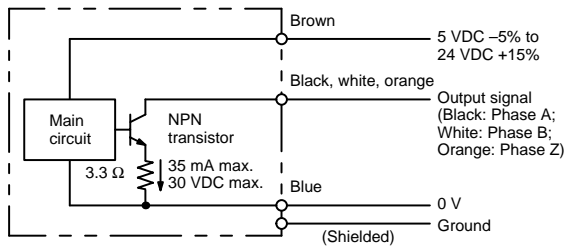

E6C2-CWZ3E

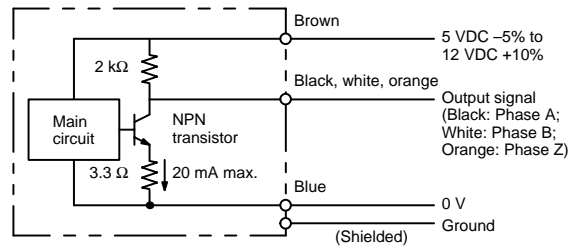

E6C2-CWZ1X/-CWZ3XH

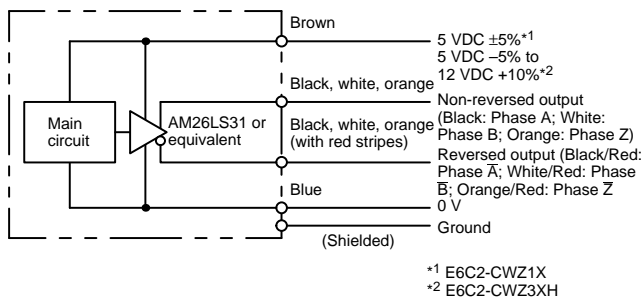

E6C2-CWZ5B

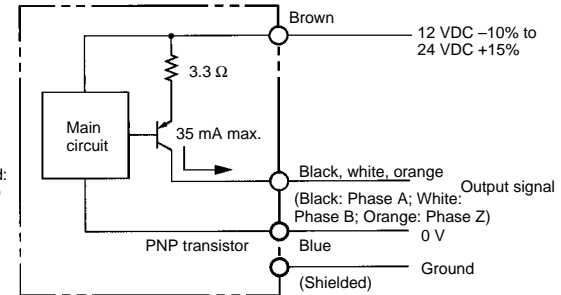

E6C2-CWZ5GH

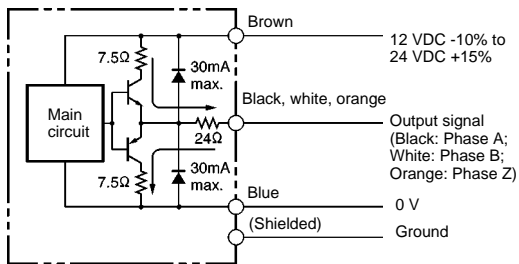

E6C2-CWZ3EH

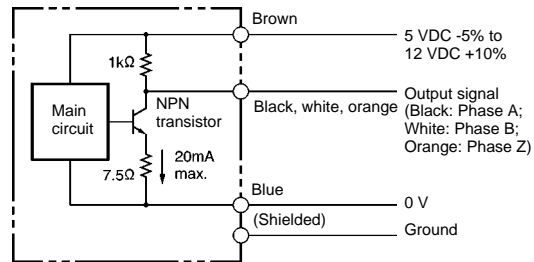

- Note:**
1. The shield is not connected to the internal circuits or casing of the E6C2-C.
 2. There is no difference in circuit among phases A, B, and Z.
 3. Connect the GND terminal to 0 V or the ground when the E6C2-C is in normal operation.

Timing Charts

NPN Open Collector Output

E6C2-CWZ6C

PNP Open Collector Output

E6C2-CWZ5B

Direction or resolution: Clockwise (CW)
(As viewed from the end of the shaft)

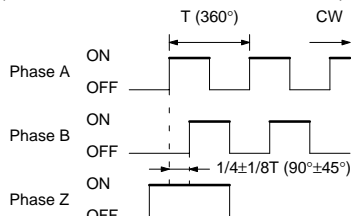

Direction or resolution: Counterclockwise (CCW)
(As viewed from the end of the shaft)

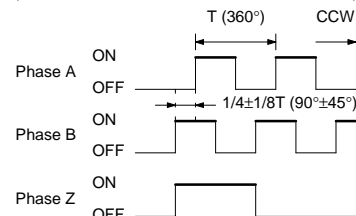

- Note:** Phase A is $1/4 \pm 1/8 T$ faster than phase B. The ONs in the above timing chart mean that the output transistor is ON and the OFFs mean that the output transistor is OFF.

- Note:** Phase A is $1/4 \pm 1/8 T$ slower than phase B.

Voltage Output

E6C2-CWZ3E, E6C2-CWZ3EH

Complementary Output: E6C2-CWZ5GH

Direction or resolution: Clockwise (CW)
(As viewed from the end of the shaft)

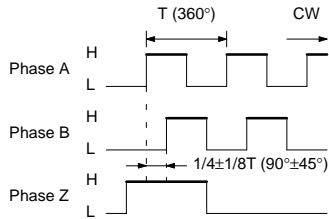

Note: Phase A is 1/4 ± 1/8T faster than phase B.

Direction or resolution: Counterclockwise (CCW)
(As viewed from the end of the shaft)

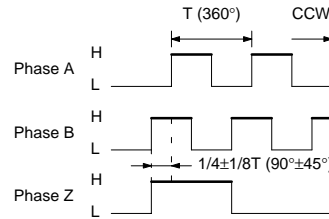

Note: Phase A is 1/4 ± 1/8T slower than phase B.

Line Driver Output

E6C2-CWZ1X, E6C2-CWZ3XH

Direction or resolution: Clockwise (CW)
(As viewed from the end of the shaft)

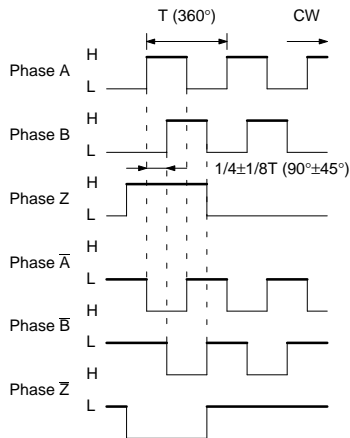

Direction or resolution: Counterclockwise (CCW)
(As viewed from the end of the shaft)

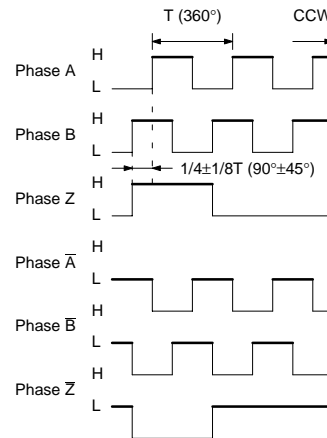

Input to More than One Counter from Encoder (with Voltage Output)

Use the following formula to obtain the number of counters to be connected to a single E6C2-C Rotary Encoder.

$$\text{Number of counters (N)} = \frac{R1 (E-V)}{V \times R2}$$

- E: Voltage supplied to Rotary Encoder
- V: Minimum input voltage of the counter
- R2: Output resistance of the Rotary Encoder
- R1: Input resistance of the Counter

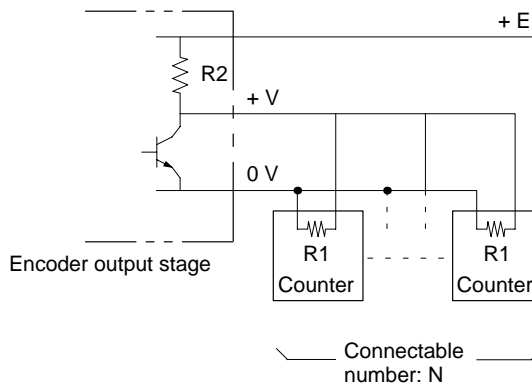

Dimensions

Note: All units are in millimeters unless otherwise indicated.

Standard Model E6C2-CWZ□□

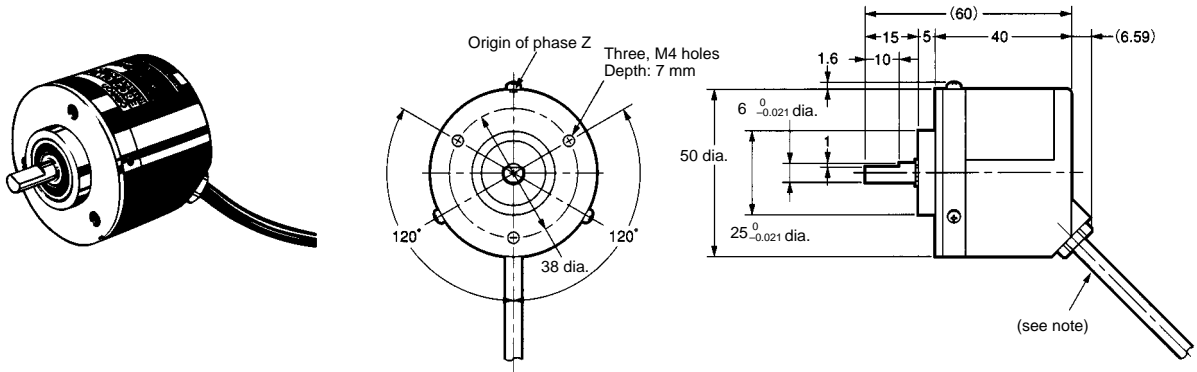

Note: 2-m-long, oil-resistive PVC cable, 5-dia. (conductor cross-section: 0.2 mm², insulator: 1.0 dia.) five conductors and shield (eight conductors for line driver use)

Solid 8-dia. Shaft Model E6C2-CWZ□□H

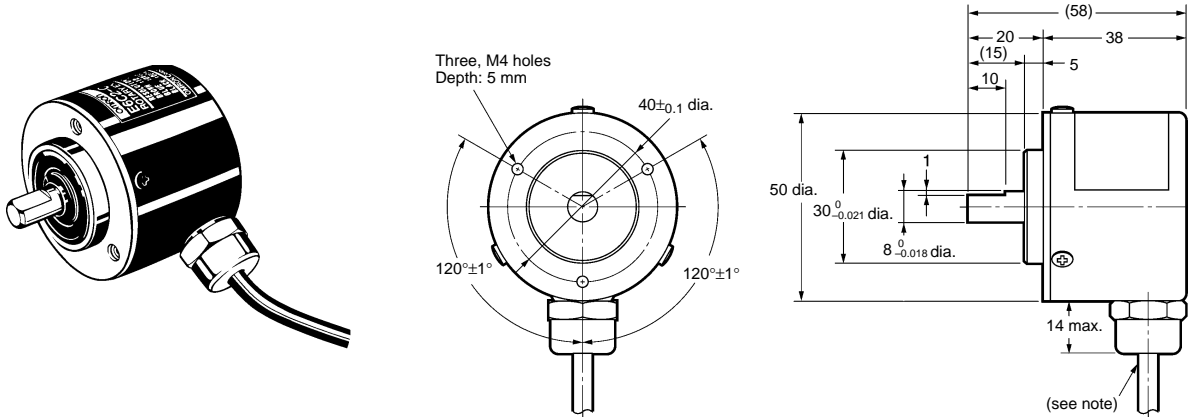

Note: 2-m-long, oil-resistive PVC cable, 5-dia. (conductor cross-section: 0.2 mm², insulator: 1.0 dia.) five conductors and shield (eight conductors for line driver use)

■ Accessories (Order Separately)

Couplings

E69-C06B

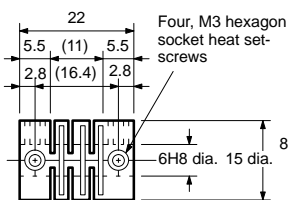

Note: The coupling is made of glass-reinforced PBT.

E69-C08B

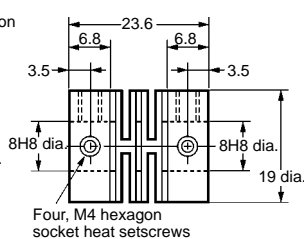

Note: The coupling is made of glass-reinforced PBT.

**E69-C68B
(With Ends of Different Diameter)**

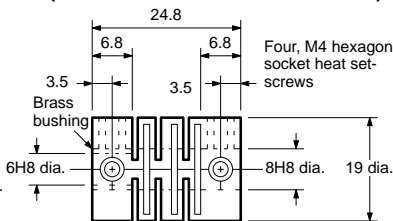

Note: The coupling is made of glass-reinforced PBT.

E69-C06M (Metal Construction)

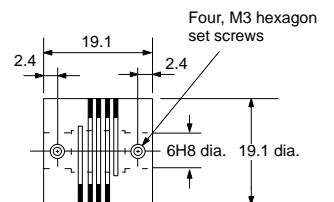

Note: Material: Super duralumin

Flanges

E69-FCA

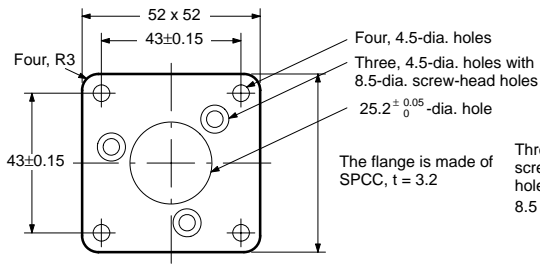

E69-FCA02

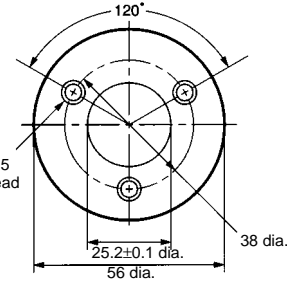

Mounting Bracket:

(A set of three Brackets provided with the E69-FCA02)

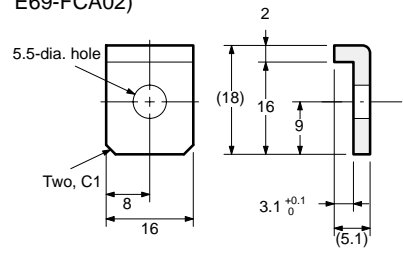

Note: Material: SPCC, t=3.2

Mounting Dimensions

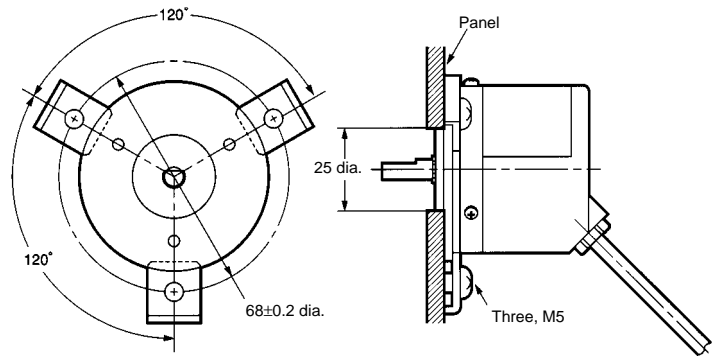

Servo Mounting Bracket

E69-2 (A Set of Three)

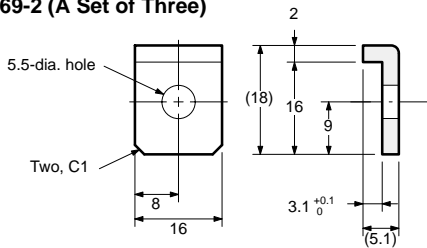

Note: A set of E69-2 Servo Mounting Brackets is provided with the E69-FCA02 Flange.

Flanges

E69-FCA03

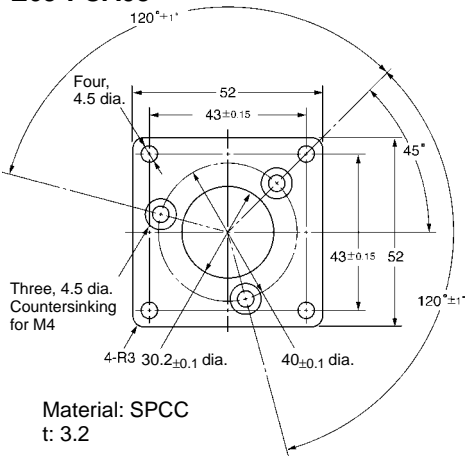

E69-FCA04

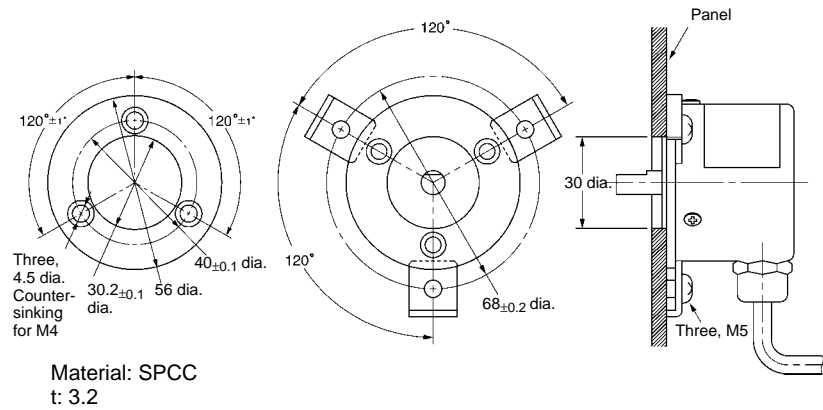

Installation

■ Connection

E6C2-CWZ6C/-CWZ3E/-CWZ5B/-CWZ5GH/-CWZ3EH

Color	Terminal
Brown	Power supply (+V _{CC})
Black	Output phase A
White	Output phase B
Orange	Output phase Z
Blue	0 V (common)

E6C2-CWZ1X/-CWZ3XH

Color	Terminal
Brown	Power supply (+V _{CC})
Black	Output phase A
White	Output phase B
Orange	Output phase Z
Black/Red stripes	Output phase A
White/Red stripes	Output phase B
Orange/Red stripes	Output phase Z
Blue	0 V (common)

Note: Receiver: AM26LS32 equivalent

■ Connection Examples

H7ER Self-powered Tachometer

Applicable Model: E6C2-CWZ3E, E6C2-CWZ3EH (with a resolution of 10 or 60 P/R)

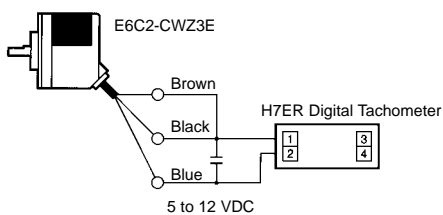

H7BR Digital Counter

Applicable Model: E6C2-CWZ3E, E6C2-CWZ3EH

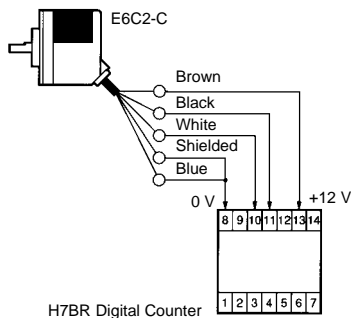

H7CR-CW Digital Counter

Applicable Model: E6C2-CWZ6C, E6C2-CWZ5GH

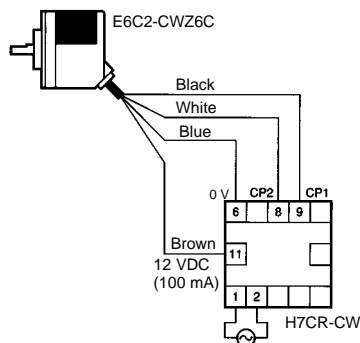

C200H-CT□□ High-speed Counter Unit

Applicable model: E6C2-CWZ6C, E6C2-CWZ5GH
Typical model: C200H-CT001-V1

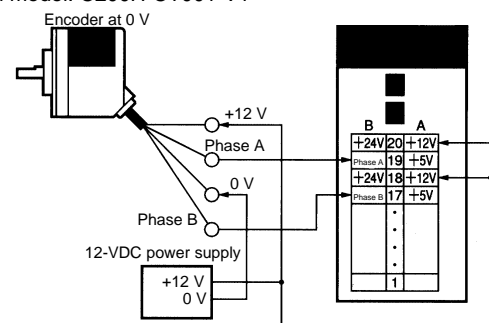

Note: Apply the following connections if the power supply to the E6C2-C is 5 or 24 V.
Phase A and Power Supply: 5 V to A19 and 24 V to B20
Phase B and Power Supply: 5 V to A17 and 24 V to B18

Applicable model: E6C2-CWZ5B, E6C2-CWZ5GH
Typical model: C200H-CT021

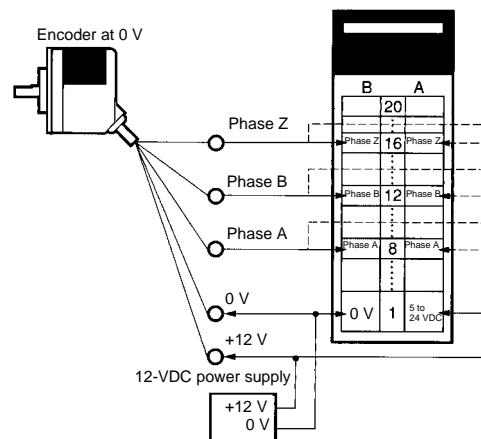

Note: Apply the following connections if the power supply to the E6C2-C is 12 or 24 V.
Phase A and Power Supply: 12 V to A8/B8 and 24 V to A9/B9
Phase B and Power Supply: 12 V to A12/B12 and 24 V to A13/B13
Phase Z and Power Supply: 12 V to A16/B16 and 24 V to A17/B17

CQM1 Programmable Controller

Applicable Model: E6C2-CWZ6C, E6C2-CWZ5GH

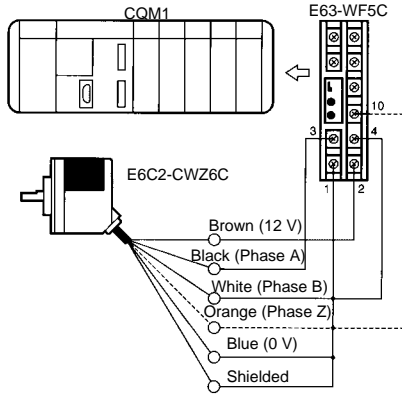

C500-CT001/CT012 High-speed Counter Unit

CW and CCW detection (increment/decrement counting)

Applicable Model: E6C2-CWZ6C, E6C2-CWZ5GH

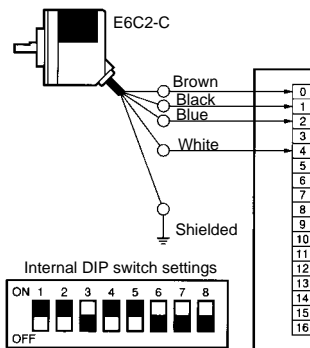

CQM1-CPU43-EV1 (as Built-in High-speed Counter)

The pulse output of the E6C2-C can be directly input into IN04, IN05, and IN06 of the CPU Unit to use these three points as a built-in high-speed counter.

The single-phase response speed is 5 kHz and the two-phase response speed is 2.5 kHz. The count value is within a range between 0 and 65,535 in increment mode and -32,767 and 32,767 in decrement mode.

The operating mode of the high-speed counter is set with the PC Setup in the DM area.

Count Mode

Up/Down mode	Increment/Decrement counter uses phases A and B.
Incrementing mode	Increment counter uses phase A only.
Normal mode	IN04 through IN06 are used for normal input.

Applicable Model: E6C2-CWZ6C, E6C2-CWZ5GH

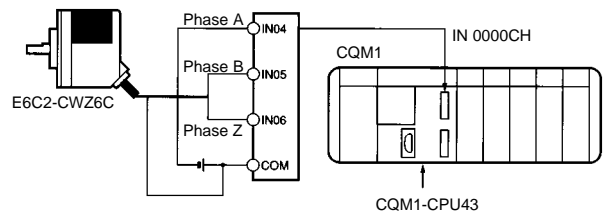

Reset

The present count value can be reset with the soft-reset function or the AND of soft reset and phase Z input.

Output

Target value	When the count value reaches the target value, the specified subroutine is executed. A maximum of 16 target values can be set.
Range comparison	When the count value is within the range, the specified subroutine is executed. A maximum of 8 ranges can be set with upper and lower limits.

Precautions

1. Do not impose voltage exceeding the rated voltage range on the E6C2-C, otherwise the E6C2-C may be damaged.
2. Be sure that the wiring of power supply to the E6C2-C is correct, otherwise the E6C2-C may be damaged.
3. Turn off the Rotary Encoder when wiring.
4. Do not wire power lines or high-tension lines along with the power supply lines of the E6C2-C Rotary Encoder or the E6C2-C Rotary Encoder may be damaged or malfunction.

Mounting

Be careful not to spray water or oil onto the E6C2-C Rotary Encoder.

The E6C2-C Rotary Encoder consists of high-precision components. Handle with utmost care and do not drop the Rotary Encoder, otherwise malfunctioning may result.

Do not pull the cable of the E6C2-C Rotary Encoder after the E6C2-C Rotary Encoder is mounted to a panel. Do not apply any shock to the hollow shaft or the body.

When the E6C2-C Rotary Encoder is used in reversed operation, pay utmost attention to the mounting direction of the E6C2-C Rotary Encoder and the directions of increment and decrement rotation.

To match phase Z of the E6C2-C Rotary Encoder and the origin of the device to be connected to the E6C2-C Rotary Encoder, conform the phase Z outputs while connecting the device.

Be careful enough not to impose an excessive load on the shaft if the shaft connects to a gear.

If the Rotary Encoder is mounted with screws, the tightening torque must be approximately 0.5 N • m.

If the Rotary Encoder is mounted to a panel, do not pull the cable with more than a force of 30 N.

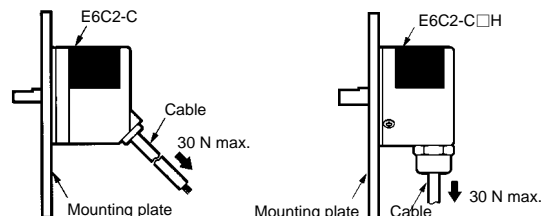

No shock must be given to the shaft or coupling. Therefore, do not hit the shaft or coupling with a hammer when inserting the shaft into the coupling.

Refer to the following illustrations when using a standard coupling.

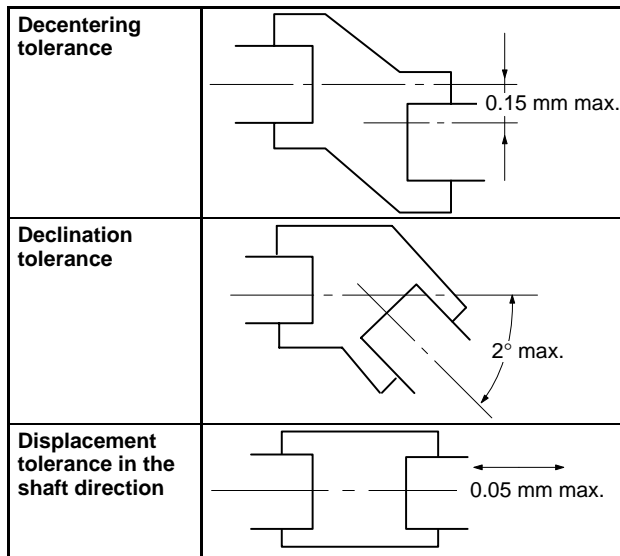

When connecting or disconnecting the coupling, do not impose an excessive bending, pressing, or pulling force on the E6C2-C.

When connecting the shaft of the Rotary Encoder with a chain timing belt or gear, connect the chain timing belt or gear with the shaft via the bearing and coupling as shown in the following illustration.

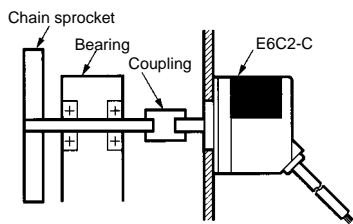

If the decentering or declination value exceeds the tolerance, an excessive load imposed on the shaft may damage the Rotary Encoder or shorten the life of the Rotary Encoder.

Life of Bearing

The following graph shows the life expectancy of the bearing with radial and thrust loads imposed on the bearing. (Theoretical)

E6C2-C

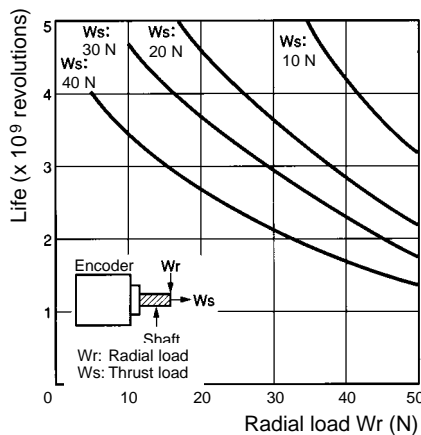

E6C2-C□H

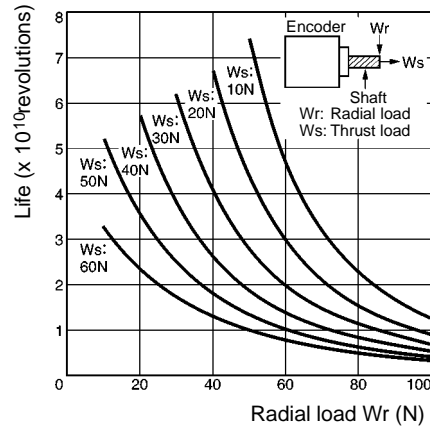

Mounting Procedure

1. Insert the shaft into the coupling.
Do not secure the coupling and shaft with screws at this stage.

2. Secure the Rotary Encoder.

Refer to the following table for the maximum insertion length of the shaft into the coupling.

Model	Maximum insertion length
E69-C06B	5.5 mm (see note 1)
E69-C06M	8.5 mm (see note 1)
E69-C08B	6.8 mm (see note 2)

3. Secure the coupling.

Model	Tightening torque
E69-C06B	0.25 N • m (see note 1)
E69-C06M	0.7 N • m (see note 1)
E69-C08B	0.44 N • m (see note 2)

- Note:**
1. Applicable to E6C2-CWZ□.
 2. Applicable to E6C2-CWZ□H.

3. Connect the power and I/O lines.

Be sure to turn off the Rotary Encoder when connecting the lines.

4. Turn on the Rotary Encoder and check the output.

Connecting

When extending the cord, select the kind of cord with care by taking the response frequency into consideration because the longer the cord is, the more the residual voltage increases due to the resistance of the cord and the capacitance between the wires. As a result, the waveform will be distorted.

We recommend the line driver output type model if the cord needs to be extended.

In order to reduce inductive noise, the cord must be as short as possible, especially when the signal is input to an IC.

Insert a surge absorber between the power supply terminals if there is any surge.

A wrong pulse may be generated when the E6C2-C Rotary Encoder is turned on or off. Do not use the connected device for 0.1 s after the E6C2-C Rotary Encoder is turned on and for 0.1 s before the E6C2-C Rotary Encoder is turned off.

Cord Extension

The rise time of each output waveform will increase when the cord is extended. This affects the phase difference characteristics of phases A and B.

The available length of cord varies with the response frequency and noise. It is safer to limit the length of cord to 10 m maximum. If a longer cord of up to 100 m is required, use line driver output.

Note: Recommended Cord:
 Cross section: 0.2 mm² with spiral shield
 Conductor resistance: 92 Ω/km max. at 20°C
 Insulation resistance: 5 MΩ/km min. at 20°C

The rise time varies with the resistance of the cord and the kind of cord as well as the length of the cord.

The residual output voltage will increase according to the length of the cord.

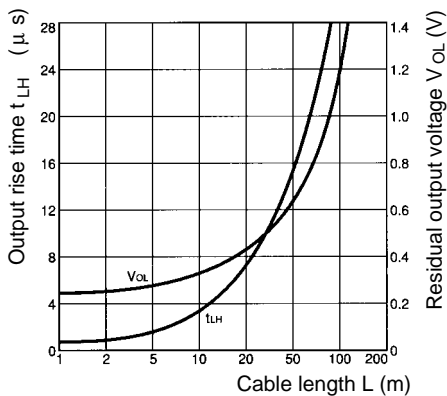

Conditions

Rotary Encoder: E6C2-CWZ6C

Load voltage: 5 VDC

Load resistance: 1 kΩ (The residual output voltages were measured with a load current of 35 mA.)

Cord: Dedicated cord

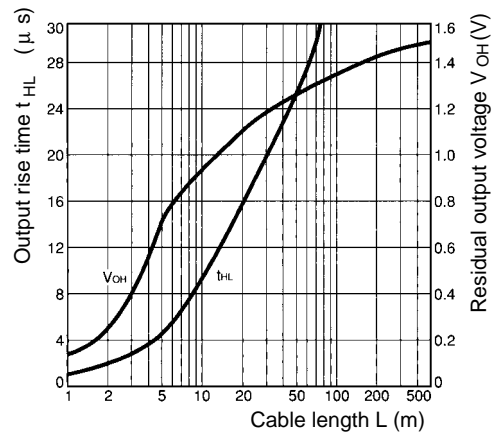

Conditions

Rotary Encoder: E6C2-CWZ5B

Load voltage: 12 VDC

Load current: 5 mA (The residual output voltages were measured with a load current of 35 mA.)

Cord: Dedicated cord

Preventing Miscounting

If the operation of the E6C2-C Rotary Encoder is stopped near a signal rising or falling edge, a wrong pulse may be generated, in which case the E6C2-C Rotary Encoder will miscount. In such a case, use an increment-decrement counter to prevent miscounting.

Extension of Line Driver Output

Be sure to use a twisted-pair cable to extend a line driver cord. Use an RS-422A Receiver for the receiver side.

The twisted-pair wires as shown in the following illustration are suitable for RS-422A signal transmission. Normal mode noise can be eliminated by twisting the wires because the generated electrical forces on the lines cancel each other.

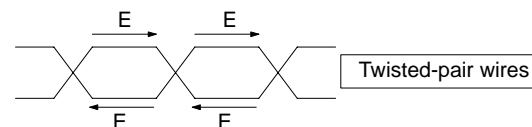

Be sure the E6C2-C Rotary Encoder is supplied with 5 VDC when a line driver output is used. There will be an approximately 1-V voltage drop if the cable length is 100 m.

ALL DIMENSIONS SHOWN ARE IN MILLIMETERS.

To convert millimeters into inches, multiply by 0.03937. To convert grams into ounces, multiply by 0.03527.

Cat. No. Q109-E1-3 In the interest of product improvement, specifications are subject to change without notice.

OMRON Corporation

Industrial Automation Company

Industrial Sensors Division
 Sensing Devices and Components Division H.Q.
 28th Fl., Crystal Tower Bldg.,
 1-2-27, Shiromi
 Chuo-ku, Osaka 540-6028 Japan
 Phone: (81)6-6949-6012 Fax: (81)6-6949-6021

Printed in Japan
 0499-2M (0997) (A)